

Contract Routing Form

ROUTING: Routine

printed on: 04/08/2020

Contract between: Scott Construction Inc
 and Dept. or Division: Engineering Division
 Name/Phone Number:

Project: Chip Sealing 2020 -East

Contract No.: 8509
 Enactment No.: RES-20-00259
 Dollar Amount: 1,552,296.84

File No.: 60049
 Enactment Date: 04/03/2020

(Please DATE before routing)

Signatures Required	Date Received	Date Signed
City Clerk	4-9-2020	4-9-2020
Director of Civil Rights	4/10/2020	4/10/2020
Risk Manager	4/13/2020	4/13/2020 RON
Finance Director	4/13/2020	4/14/2020
City Attorney	4/15/2020	4/17/2020 PAL
Mayor	4/20/2020	4/21/2020

Please return signed Contracts to the City Clerk's Office
 Room 103, City-County Building for filing.

Original + 2 Copies

04/08/2020 16:25:08 enjls - Steve Sonntag 267-1997

Dis Rights: OK / N/A / Problem - Hold
 Prev Wage: AA / Agency / No
 Contract Value: See above
 AA Plan: Approved
 Amendment / Addendum # _____
 Type: POS / Dwp / Sbdv / Gov't /
 Grant / PW / Goal / Loan / Agrmt



Legislation Details (With Text)

File #: 60049 **Version:** 1 **Name:** Awarding Public Works Contract No. 8509, Chip Sealing 2020 East.

Type: Resolution **Status:** Passed

File created: 3/18/2020 **In control:** Engineering Division

On agenda: 3/31/2020 **Final action:** 3/31/2020

Enactment date: 4/3/2020 **Enactment #:** RES-20-00259

Title: Awarding Public Works Contract No. 8509, Chip Sealing 2020 East. (3rd, 12th, 15th & 17th ADs)

Sponsors: BOARD OF PUBLIC WORKS

Indexes:

Code sections:

Attachments: 1. 8509.pdf, 2. Contract 8509.pdf

Date	Ver.	Action By	Action	Result
3/31/2020	1	COMMON COUNCIL	Adopt Under Suspension of Rules 2.04, 2.05, 2.24, and 2.25	Pass
3/25/2020	1	BOARD OF PUBLIC WORKS		
3/18/2020	1	Engineering Division	Refer	

The proposed resolution awards the contract for Chip Sealing 2020 East at a total cost of \$1,598,870, including contingency. Funding is provided by non-general fund GO borrowing in the 2020 Adopted Capital Budget for Engineering - Major Streets Pavement Management (MUNIS 12690-402-200), and in the 2020 Adopted Operating Budget for Streets Sealcoating (44552-54250-00000). No additional appropriation is required.

Awarding Public Works Contract No. 8509, Chip Sealing 2020 East. (3rd, 12th, 15th & 17th ADs)
 BE IT RESOLVED, that the following low bids for miscellaneous improvements be accepted and that the Mayor and City Clerk be and are hereby authorized and directed to enter into a contract with the low bidder contained herein, subject to the Contractor's compliance with Section 39.02 of the Madison General Ordinances concerning compliance with the Affirmative Action provisions **and subject to the Contractor's compliance with Section 33.07 of the Madison General Ordinances regarding Best Value Contracting:**

BE IT FURTHER RESOLVED, that the funds be encumbered to cover the cost of the projects contained herein.

See attached document (Contract No. 8509) for itemization of bids.

PROJECT

CONTRACTOR

AMOUNT OF BID

CONTRACT NO. 8509
CHIP SEALING 2020 - EAST

SCOTT CONSTRUCTION, INC.

\$1,552,296.84

Acct. No. 12690-402-200:54410 (91384)	\$1,478,560.93
Contingency 3%±	<u>44,359.07</u>
Sub-Total	\$1,522,920.00

Acct. No. 44552-54250-00000 (91384)	\$73,735.91
Contingency 3%±	<u>2,214.09</u>
Sub-Total	\$75,950.00

GRAND TOTAL	<u>\$1,598,870.00</u>
-------------	-----------------------

Jurisdiction: Wisconsin

Demographics

Company Name: Fidelity and Deposit Company of Maryland	NAIC CoCode: 39306	Short Name:
SBS Company Number: 54219634	State of Domicile: Illinois	FEIN: 13-3046577
Domicile Type: Foreign	Organization Type: Stock	Country of Domicile: United States
NAIC Group Number: 212 - ZURICH INS GRP		Date of Incorporation: 03/18/1969
Merger Flag: No		

Address

Business Address	Mailing Address	Statutory Home Office Address	Main Administrative Office Address
1299 ZURICH WAY Schaumburg, IL 60196-1056 United States	1299 ZURICH WAY Schaumburg, IL 60196-1056 United States	1299 ZURICH WAY Schaumburg, IL 60196-1056 United States	1299 ZURICH WAY Schaumburg, IL 60196-1056 United States

Phone, Email, Website

Phone	Email	Website								
<table border="1"> <thead> <tr> <th>Type</th> <th>Number</th> </tr> </thead> <tbody> <tr> <td>Toll Free Phone</td> <td>(800) 382-2150</td> </tr> <tr> <td>Business Primary Phone</td> <td>(847) 413-5048</td> </tr> <tr> <td>Business Primary Phone</td> <td>(847) 605-6000</td> </tr> </tbody> </table>	Type	Number	Toll Free Phone	(800) 382-2150	Business Primary Phone	(847) 413-5048	Business Primary Phone	(847) 605-6000	No results found.	No results found.
Type	Number									
Toll Free Phone	(800) 382-2150									
Business Primary Phone	(847) 413-5048									
Business Primary Phone	(847) 605-6000									

Company Type

Company Type: Property and Casualty	Status Reason:	Status Date: 01/01/1982
Status: Active	Legacy State ID: 111700	Expiration Date:
Effective Date: 12/31/2018	Approval Date:	File Date:
Issue Date: 01/01/1982	Article No:	COA Number:
Articles of Incorporation Received: No		

Appointments

Show entries Showing 1 to 10 of 1408 entries

Licensee Name	License Number	NPN	License Type	Line of Authority	Appointment Date	Effective Date	Expiration Date
PATRICK MCKENNA	650765	650765	Intermediary (Agent) Individual	Property	07/23/1996	01/08/2020	03/15/2021
PATRICK MCKENNA	650765	650765	Intermediary (Agent) Individual	Casualty	07/23/1996	01/08/2020	03/15/2021
PATRICK MCCLONE	129855	129855	Intermediary (Agent) Individual	Property	06/10/1991	01/08/2020	03/15/2021
PATRICK COLLENTINE	7411247	7411247	Intermediary (Agent) Individual	Property	10/20/2011	01/08/2020	03/15/2021
PATRICK WILLIAMS	956373	956373	Intermediary (Agent) Individual	Property	12/27/2013	01/08/2020	03/15/2021
PATRICK PRIBYL	4893005	4893005	Intermediary (Agent) Individual	Property	02/18/2004	01/08/2020	03/15/2021
PATRICK DICKENSHIED	298136	298136	Intermediary (Agent) Individual	Property	01/31/1983	01/08/2020	03/15/2021
PATRICK LEMIRE	9001428	9001428	Intermediary (Agent) Individual	Property	03/27/2007	01/08/2020	03/15/2021
PATRICK KELLY	372092	372092	Intermediary (Agent) Individual	Property	02/02/2017	01/08/2020	03/15/2021
PATRICK MCCLONE	129855	129855	Intermediary (Agent) Individual	Casualty	06/10/1991	01/08/2020	03/15/2021

Line Of Business

Line of Business	Citation Type	Effective Date
Aircraft	Aircraft	01/01/1982
Automobile	Automobile	01/01/1982
Credit Insurance	Credit Insurance	01/01/1982
Fidelity Insurance	Fidelity Insurance	01/01/1982
Fire, Inland Marine and Other Property Insurance	Fire, Inland Marine and Other Property Insurance	01/01/1982
Liability and Incidental Medical Expense Insurance (other than automobile)	Liability and Incidental Medical Expense Insurance (other than automobile)	01/01/1982
Miscellaneous	Miscellaneous	01/01/1982
Ocean Marine Insurance	Ocean Marine Insurance	01/01/1982
Surety Insurance	Surety Insurance	01/01/1982
Workers Compensation Insurance	Workers Compensation Insurance	01/01/1982

Contact

Contact Type	Preferred Name	Name	E-mail	Phone	Address
© 2019 National Association of Insurance Commissioners. All rights reserved.					

Contact Type	Preferred Name	Name	E-mail	Phone	Address
Registered Agent for Service of Process		*			Other CORPORATION SERVICE COMPANY 8040 EXCELSIOR DR STE 400 MADISON, WI United States County 53717

Company Merger

No results found.

Name Change History

Previous Name	New Name	Effective Date
	Fidelity and Deposit Company of Maryland	

\$1,552,296.84
FILE COPY

BID OF SCOTT CONSTRUCTION INC.

2020

PROPOSAL, CONTRACT, BOND AND SPECIFICATIONS

FOR

CHIP SEALING 2020 - EAST

CONTRACT NO. 8509

PROJECT NO. 12690

IN

MADISON, DANE COUNTY, WISCONSIN

AWARDED BY THE COMMON COUNCIL
MADISON, WISCONSIN ON MARCH 31, 2020

CITY ENGINEERING DIVISION
1600 EMIL STREET
MADISON, WISCONSIN 53713

<https://bidexpress.com/login>

**CHIP SEALING 2020 - EAST
CONTRACT NO. 8509**

INDEX

SECTION A: ADVERTISEMENT FOR BIDS AND INSTRUCTIONS TO BIDDERSA-1
SECTION B: PROPOSAL SECTION.....B-1
SECTION C: SMALL BUSINESS ENTERPRISE C-1
SECTION D: SPECIAL PROVISIONS..... D-1
SECTION E: BIDDER'S ACKNOWLEDGEMENTE-1
SECTION F: BEST VALUE CONTRACTINGF-1
SECTION G: BID BOND..... G-1
SECTION H: AGREEMENT..... H-1
SECTION I: PAYMENT AND PERFORMANCE BOND I-1

This Proposal, and Agreement have
been prepared by:

**CITY ENGINEERING DIVISION
CITY OF MADISON
MADISON, DANE COUNTY, WISCONSIN**



Robert F. Phillips, P.E., City Engineer

RFP: sms

SECTION A: ADVERTISEMENT FOR BIDS AND INSTRUCTIONS TO BIDDERS

REQUEST FOR BID FOR PUBLIC WORKS CONSTRUCTION CITY OF MADISON, WISCONSIN

A BEST VALUE CONTRACTING MUNICIPALITY

PROJECT NAME:	CHIP SEALING 2020 - EAST
CONTRACT NO.:	8509
SBE GOAL	5%
BID BOND	5%
SBE PRE BID MEETING (1:00 P.M.)	MARCH 13, 2020
PREQUALIFICATION APPLICATION DUE (2:00 P.M.)	MARCH 12, 2020
BID SUBMISSION (2:00 P.M.)	MARCH 19, 2020
BID OPEN (2:30 P.M.)	MARCH 19, 2020
PUBLISHED IN WSJ	MARCH 5 & MARCH 12, 2020

SBE PRE BID MEETING: Representatives of the Affirmative Action Department will be present to discuss the Small Business Enterprise requirements at 1600 Emil Street, Madison Wisconsin.

PREQUALIFICATION APPLICATION: Forms are available on our website, www.cityofmadison.com/business/pw/forms.cfm. If not currently prequalified in the categories listed in Section A, an amendment to your Prequalification will need to be submitted prior to the same due date. Postmark is not applicable.

BIDS TO BE SUBMITTED by hand to 1600 EMIL ST., MADISON, WI 53713 or online at www.bidexpress.com.

THE BID OPENING is at 1600 EMIL ST., MADISON, WI 53713.

STANDARD SPECIFICATIONS

The City of Madison's Standard Specifications for Public Works Construction - 2020 Edition, as supplemented and amended from time to time, forms a part of these contract documents as if attached hereto.

These standard specifications are available on the City of Madison Public Works website, www.cityofmadison.com/Business/PW/specs.cfm.

The Contractor shall review these Specifications prior to preparation of proposals for the work to be done under this contract, with specific attention to Article 102, "BIDDING REQUIREMENTS AND CONDITIONS" and Article 103, "AWARD AND EXECUTION OF THE CONTRACT." For the convenience of the bidder, below are highlights of three subsections of the specifications.

SECTION 102.1: PRE-QUALIFICATION OF BIDDERS

In accordance with Wisconsin State Statutes 66.0901 (2) and (3), all bidders must submit to the Board of Public Works proof of responsibility on forms furnished by the City. The City requires that all bidders be qualified on a biennial basis.

Bidders must present satisfactory evidence that they have been regularly engaged in the type of work specified herein and they are fully prepared with necessary capital, materials, machinery and supervisory personnel to conduct the work to be contracted for to the satisfaction of the City. All bidders must be pre-qualified by the Board of Public Works for the type of construction on which they are bidding prior to the opening of the bid.

In accordance with Section 39.02(9)(a)l. of the General Ordinances, all bidders shall submit in writing to the Affirmative Action Division Manager of the City of Madison, a Certificate of Compliance or an Affirmative Action Plan at the same time or prior to the submission of the proof of responsibility forms.

The bidder shall be disqualified if the bidder fails to or refuses to, prior to opening of the bid, submit a Certificate of compliance, Affirmative Action Plan or Affirmative Action Data Update, as applicable, as defined by Section 39.02 of the General Ordinances (entitled Affirmative Action) and as required by Section 102.11 of the Standard Specifications.

SECTION 102.4 PROPOSAL

No bid will be accepted that does not contain an adequate or reasonable price for each and every item named in the Schedule of Unit Prices.

A lump sum bid for the work in accordance with the plans and specifications is required. The lump sum bid must be the same as the total amounts bid for the various items and it shall be inserted in the space provided.

All papers bound with or attached to the proposal form are considered a part thereof and must not be detached or altered when the proposal is submitted. The plans, specifications and other documents designated in the proposal form will be considered a part of the proposal whether attached or not.

A proposal submitted by an individual shall be signed by the bidder or by a duly authorized agent. A proposal submitted by a partnership shall be signed by a member/partner or by a duly authorized agent thereof. A proposal submitted by a corporation shall be signed by an authorized officer or duly authorized registered agent of such corporation, and the proposal shall show the name of the State under the laws of which such corporation was chartered. The required signatures shall in all cases appear in the space provided thereof on the proposal.

Each proposal shall be placed, together with the proposal guaranty, in a sealed envelope, so marked as to indicate name of project, the contract number or option to which it applies, and the name and address of the Contractor or submitted electronically through Bid Express (www.bidexpress.com). Proposals will be accepted at the location, the time and the date designated in the advertisement. Proposals received after the time and date designated will be returned to the bidder unopened.

SECTION 102.5: BID DEPOSIT (PROPOSAL GUARANTY)

All bids, sealed or electronic, must be accompanied with a Bid Bond (City of Madison form) equal to at least 5% of the bid or a Certificate of Annual/Biennial Bid Bond or certified check, payable to the City Treasurer. Bid deposit of the successful bidders shall be returned within forty-eight (48) hours following execution of the contract and bond as required.

MINOR DISCREPENCIES

Bidder is responsible for submitting all forms necessary for the City to determine compliance with State and City bidding requirements. Notwithstanding any language to the contrary contained herein, the City may exercise its discretion to allow bidders to correct or supplement submissions after bid opening, if the minor discrepancy, bid irregularity or omission is insignificant and not one related to price, quality, quantity, time of completion or performance of the contract.

Bidders for this Contract(s) must be Pre-Qualified for at least one of the following type(s) of construction denoted by an

Building Demolition

- 101 Asbestos Removal
- 120 House Mover

- 110 Building Demolition

Street, Utility and Site Construction

- 201 Asphalt Paving
- 205 Blasting
- 210 Boring/Pipe Jacking
- 215 Concrete Paving
- 220 Con. Sidewalk/Curb & Gutter/Misc. Flat Work
- 221 Concrete Bases and Other Concrete Work
- 222 Concrete Removal
- 225 Dredging
- 230 Fencing
- 235 Fiber Optic Cable/Conduit Installation
- 240 Grading and Earthwork
- 241 Horizontal Saw Cutting of Sidewalk
- 242 Infrared Seamless Patching
- 245 Landscaping, Maintenance
- 246 Ecological Restoration
- 250 Landscaping, Site and Street
- 251 Parking Ramp Maintenance
- 252 Pavement Marking
- 255 Pavement Sealcoating and Crack Sealing
- 260 Petroleum Above/Below Ground Storage Tank Removal/Installation
- 262 Playground Installer

- 265 Retaining Walls, Precast Modular Units
- 270 Retaining Walls, Reinforced Concrete
- 275 Sanitary, Storm Sewer and Water Main Construction
- 276 Sawcutting
- 280 Sewer Lateral Drain Cleaning/Internal TV Insp.
- 285 Sewer Lining
- 290 Sewer Pipe Bursting
- 295 Soil Borings
- 300 Soil Nailing
- 305 Storm & Sanitary Sewer Laterals & Water Svc.
- 310 Street Construction
- 315 Street Lighting
- 318 Tennis Court Resurfacing
- 320 Traffic Signals
- 325 Traffic Signing & Marking
- 332 Tree pruning/removal
- 333 Tree, pesticide treatment of
- 335 Trucking
- 340 Utility Transmission Lines including Natural Gas, Electrical & Communications
- 399 Other _____

Bridge Construction

- 501 Bridge Construction and/or Repair

Building Construction

- 401 Floor Covering (including carpet, ceramic tile installation, rubber, VCT)
- 402 Building Automation Systems
- 403 Concrete
- 404 Doors and Windows
- 405 Electrical - Power, Lighting & Communications
- 410 Elevator - Lifts
- 412 Fire Suppression
- 413 Furnishings - Furniture and Window Treatments
- 415 General Building Construction, Equal or Less than \$250,000
- 420 General Building Construction, \$250,000 to \$1,500,000
- 425 General Building Construction, Over \$1,500,000
- 428 Glass and/or Glazing
- 429 Hazardous Material Removal
- 430 Heating, Ventilating and Air Conditioning (HVAC)
- 433 Insulation - Thermal
- 435 Masonry/Tuck pointing

- 437 Metals
- 440 Painting and Wallcovering
- 445 Plumbing
- 450 Pump Repair
- 455 Pump Systems
- 460 Roofing and Moisture Protection
- 464 Tower Crane Operator
- 461 Solar Photovoltaic/Hot Water Systems
- 465 Soil/Groundwater Remediation
- 466 Warning Sirens
- 470 Water Supply Elevated Tanks
- 475 Water Supply Wells
- 480 Wood, Plastics & Composites - Structural & Architectural
- 499 Other _____

State of Wisconsin Certifications

- 1 Class 5 Blaster - Blasting Operations and Activities 2500 feet and closer to inhabited buildings for quarries, open pits and road cuts.
- 2 Class 6 Blaster - Blasting Operations and Activities 2500 feet and closer to inhabited buildings for trenches, site excavations, basements, underwater demolition, underground excavations, or structures 15 feet or less in height.
- 3 Class 7 Blaster - Blasting Operations and Activities for structures greater than 15' in height, bridges, towers, and any of the objects or purposes listed as "Class 5 Blaster or Class 6 Blaster".
- 4 Petroleum Above/Below Ground Storage Tank Removal and Installation (Attach copies of State Certifications.)
- 5 Hazardous Material Removal (Contractor to be certified for asbestos and lead abatement per the Wisconsin Department of Health Services, Asbestos and Lead Section (A&LS).) See the following link for application: www.dhs.wisconsin.gov/Asbestos/Cert. State of Wisconsin Performance of Asbestos Abatement Certificate must be attached.
- 6 Certification number as a Certified Arborist or Certified Tree Worker as administered by the International Society of Arboriculture
- 7 Pesticide application (Certification for Commercial Applicator For Hire with the certification in the category of turf and landscape (3.0) and possess a current license issued by the DATCP)
- 8 State of Wisconsin Master Plumbers License.

SECTION B: PROPOSAL

Please refer to the
Bid Express Website
at <https://bidexpress.com>
look up contract number
and go to
Section B: Proposal Page

You can access all City of Madison bid solicitations for FREE at www.bidexpress.com

Click on the "Register for Free" button and follow the instructions to register your company and yourself. You will be asked for a payment subscription preference, since you may wish to bid online someday. Simply choose the method to pay on a 'per bid' basis. This requires no payment until / unless you actually bid online. You can also choose the monthly subscription plan at this time. You will, however, be asked to provide payment information. Remember, you can change your preference at anytime. You will then be able to complete your free registration and have full access to the site. Your free access does not require completion of the 'Digital ID' process, so you will have instant access for viewing and downloading. To be prepared in case you ever do wish to bid online, you may wish to establish your digital ID also, since you cannot bid without a Digital ID.

If you have any problems with the free registration process, you can call the bidexpress help team, toll free at 1-888-352-2439 (option 1, option1).

SECTION C: SMALL BUSINESS ENTERPRISE

Instructions to Bidders City of Madison SBE Program Information

2 Small Business Enterprise (SBE) Program Information

2.1 Policy and Goal

The City of Madison reaffirms its policy of nondiscrimination in the conduct of City business by maintaining a procurement process which remains open to all who have the potential and ability to sell goods and services to the City. It is the policy of the City of Madison to allow Small Business Enterprises (SBE) maximum feasible opportunity to participate in City of Madison contracting. The bidder acknowledges that its bid has been submitted in accordance with the SBE program and is for the public's protection and welfare.

Please refer to the "ADVERTISEMENT FOR BIDS" for the goal for the utilization of SBEs on this project. SBEs may participate as subcontractors, vendors and/or suppliers, which provide a commercially useful function. The dollar value for SBE suppliers or 'materials only' vendors shall be discounted to 60% for purposes of meeting SBE goals.

A bidder which achieves or exceeds the SBE goal will be in compliance with the SBE requirements of this project. In the event that the bidder is unable to achieve the SBE goal, the bidder must demonstrate that a good faith effort to do so was made. Failure to either achieve the goal or demonstrate a good faith effort to do so will be grounds for the bidder being deemed a non-responsible contractor ineligible for award of this contract.

A bidder may count towards its attainment of the SBE goal only those expenditures to SBEs that perform a commercially useful function. For purposes of evaluating a bidder's responsiveness to the attainment of the SBE goal, the contract participation by an SBE is based on the percentage of the total base bid proposed by the Contractor. The total base bid price is inclusive of all addenda.

Work performed by an SBE firm in a particular transaction can be counted toward the goal only if it involves a commercially useful function. That is, in light of industry practices and other relevant considerations, does the SBE firm have a necessary and useful role in the transaction, of a kind for which there is a market outside the context of the SBE Program, or is the firm's role a superfluous step added in an attempt to obtain credit towards goals? If, in the judgment of the Affirmative Action Division, the SBE firm will not perform a commercially useful function in the transaction, no credit towards goals will be awarded.

The question of whether a firm is performing a commercially useful function is completely separate from the question of whether the firm is an eligible SBE. A firm is eligible if it meets the definitional criteria and ownership and control requirements, as set forth in the City of Madison's SBE Program.

If the City of Madison determines that the SBE firm is performing a commercially useful function, then the City of Madison must then decide what that function is. If the commercially useful function is that of an SBE vendor / supplier that regularly transacts business with the respective product, then the City of Madison will count 60% of the value of the product supplied toward SBE goals.

To be counted, the SBE vendor / supplier must be engaged in selling the product in question to the public. This is important in distinguishing an SBE vendor / supplier, which has a regular trade with a variety of customers, from a firm which performs supplier-like functions on an ad hoc basis or for only one or two contractors with whom it has a special relationship.

A supplier of bulk goods may qualify as an eligible SBE vendor / supplier if it either maintains an inventory or owns or operates distribution equipment. With respect to the distribution equipment; e.g., a fleet of trucks, the term "operates" is intended to cover a situation in which the supplier leases the equipment on a regular basis for its entire business. It is not intended to cover a situation in which the firm simply provides drivers for trucks owned or leased by another party; e.g., a prime contractor, or leases such a party's trucks on an ad hoc basis for a specific job.

If the commercially useful function being performed is not that of a qualified SBE vendor / supplier, but rather that of delivery of products, obtaining bonding or insurance, procurement of personnel, acting as a broker or manufacturer's representative in the procurement of supplies, facilities, or materials, etc., only the fees or commissions will apply towards the goal.

For example, a business that simply transfers title of a product from manufacturer to ultimate purchaser; e. g., a sales representative who re-invoices a steel product from the steel company to the Contractor, or a firm that puts a product into a container for delivery would not be considered a qualified SBE vendor / supplier. The Contractor would not receive credit based on a percentage of the cost of the product for working with such firms.

Concerning the use of services that help the Contractor obtain needed supplies, personnel, materials or equipment to perform a contract: only the fee received by the service provider will be counted toward the goal. For example, use of a SBE sales representative or distributor for a steel company, if performing a commercially useful function at all, would entitle the Contractor receiving the steel to count only the fee paid to the representative or distributor toward the goal. This provision would also govern fees for professional and other services obtained expressly and solely to perform work relating to a specific contract.

Concerning transportation or delivery services: if an SBE trucking company picks up a product from a manufacturer or a qualified vendor / supplier and delivers the product to the Contractor, the commercially useful function it is performing is not that of a supplier, but simply that of a transporter of goods. Unless the trucking company is itself the manufacturer or a qualified vendor / supplier in the product, credit cannot be given based on a percentage of the cost of the product. Rather, credit would be allowed for the cost of the transportation service.

The City is aware that the rule's language does not explicitly mention every kind of business that may contribute work on this project. In administering these programs, the City would, on a case-by-case basis, determine the appropriate counting formula to apply in a particular situation.

2.2 Contract Compliance

Questions concerning the SBE Program shall be directed to the Contract Compliance Officer of the City of Madison Department of Civil Rights, Affirmative Action Division, 210 Martin Luther King, Jr. Blvd., Room 523, Madison, WI 53703; telephone (608) 266-4910.

2.3 Certification of SBE by City of Madison

The Affirmative Action Division maintains a directory of SBEs which are currently certified as such by the City of Madison. Contact the Contract Compliance Officer as indicated in Section 2.2 to receive a copy of the SBE Directory or you may access the SBE Directory online at www.cityofmadison.com/civil-rights/contract-compliance/targeted-business-enterprise-programs/targeted-business-enterprise.

All contractors, subcontractors, vendors and suppliers seeking SBE status must complete and submit the **Targeted Business Certification Application** to the City of Madison Affirmative Action Division by the time and date established for receipt of bids. A copy of the Targeted Business Certification Application is available by contacting the Contract Compliance Officer at the address and telephone indicated in Section 2.2 or you may access the Targeted Business Certification Application online at www.cityofmadison.com/civil-rights/contract-compliance/targeted-business-enterprise-programs/targeted-business-enterprise. Submittal of the Targeted Business Certification Application by the time specified does not guarantee that the applicant will be certified as a SBE eligible to be utilized towards meeting the SBE goal for this project.

2.4 Small Business Enterprise Compliance Report

2.4.1 Good Faith Efforts

Bidders shall take all necessary affirmative steps to assure that SBEs are utilized when possible and that the established SBE goal for this project is achieved. A contractor who self performs a portion of the work, and is pre-qualified to perform that category of work, may subcontract that portion of the work, but shall not be required to do so. When a bidder is unable to achieve the established SBE goal, the bidder must demonstrate that a good faith effort to do so was made. Such a good faith effort should include the following:

- 2.4.1.1 Attendance at the pre-bid meeting.
- 2.4.1.2 Using the City of Madison's directory of certified SBEs to identify SBEs from which to solicit bids.
- 2.4.1.3 Assuring that SBEs are solicited whenever they are potential sources.
- 2.4.1.4 Referring prospective SBEs to the City of Madison Affirmative Action Division for certification.
- 2.4.1.5 Dividing total project requirements into smaller tasks and/or quantities, where economically feasible, to permit maximum feasible SBE participation.
- 2.4.1.6 Establishing delivery schedules, where requirements permit, which will encourage participation by SBEs.
- 2.4.1.7 Providing SBEs with specific information regarding the work to be performed.
- 2.4.1.8 Contacting SBEs in advance of the deadline to allow such businesses sufficient time to prepare a bid.
- 2.4.1.9 Utilizing the bid of a qualified and competent SBE when the bid of such a business is deemed reasonable (i.e. 5% above the lowest bidder), although not necessarily low.
- 2.4.1.10 Contacting SBEs which submit a bid, to inquire about the details of the bid and confirm that the scope of the work was interpreted as intended.
- 2.4.1.11 Completion of Cover Page (page C-6), Summary Sheet (page C-7) and SBE Contact Reports (pages C-8 and C9) if applicable.

2.4.2 Reporting SBE Utilization and Good Faith Efforts

The Small Business Enterprise Compliance Report is to be submitted by the bidder with the bid. This report is due by the specified bid closing time and date. Bids submitted without a completed SBE Compliance Report as outlined below may be deemed non-responsible and the bidder ineligible for award of this contract. Notwithstanding any language to the contrary contained herein, the City may exercise its discretion to allow bidders to correct or supplement submissions after bid opening, if the minor discrepancy, bid irregularity or omission is insignificant and not one related to price, quality, quantity, time of completion, performance of the contract, or percentage of SBE utilization.

2.4.2.1 If the Bidder meets or exceeds the goal established for SBE utilization, the Small Business Enterprise Compliance Report shall consist of the following:

- 2.4.2.1.1 **Cover Page**, Page C-6; and
- 2.4.2.1.2 **Summary Sheet**, C-7.

2.4.2.2 If the bidder does not meet the goal established for SBE utilization, the Small Business Enterprise Compliance Report shall consist of the following:

- 2.4.2.2.1 **Cover Page**, Page C-6;
- 2.4.2.2.2 **Summary Sheet**, C-7; and
- 2.4.2.2.3 **SBE Contact Report**, C-8 and C-9. (A separate Contact Report must be completed for each applicable SBE which is not utilized.)

2.5 Appeal Procedure

A bidder which does not achieve the established goal and is found non-responsible for failure to demonstrate a good faith effort to achieve such goal and subsequently denied eligibility for award of contract may appeal that decision to the Small Business Enterprises Appeals Committee. All appeals shall be made in writing, and shall be delivered to and received by the City Engineer no later than 4:30 PM on the third business day following the bidder's receipt of the written notification of ineligibility by the Affirmative Action Division Manager. Postmark not acceptable. The notice of appeal shall state the basis for the appeal of the decision of the Affirmative Action Division Manager. The Appeal shall take place in accordance with Madison General Ordinance 33.54.

2.6 SBE Requirements After Award of the Contract

The successful bidder shall identify SBE subcontractors, suppliers and vendors on the subcontractor list in accordance with the specifications. The Contractor shall submit a detailed explanation of any variances between the listing of SBE subcontractors, vendors and/or suppliers on the subcontractor list and the Contractor's SBE Compliance Report for SBE participation.

No change in SBE subcontractors, vendors and/or suppliers from those SBEs indicated in the SBE Compliance Report will be allowed without prior approval from the Engineer and the Affirmative Action Division. The contractor shall submit in writing to the City of Madison Affirmative Action Division a request to change any SBE citing specific reasons which necessitate such a change. The Affirmative Action Division will use a general test of reasonableness in approving or rejecting the contractor's request for change. If the request is approved, the Contractor will make every effort to utilize another SBE if available.

The City will monitor the project to ensure that the actual percentage commitment to SBE firms is carried out.

2.7 SBE Definition and Eligibility Guidelines

A Small Business Enterprise is a business concern awarded certification by the City of Madison. For the purposes of this program a Small Business Enterprise is defined as:

- A. An independent business operated under a single management. The business may not be a subsidiary of any other business and the stock or ownership may not be held by any individual or any business operating in the same or a similar field. In determining whether an entity qualifies as a SBE, the City shall consider all factors relevant to being an independent business including, but not limited to, the date the business was established, adequacy of its resources for the work in which it proposes to involve itself, the degree to which financial, equipment leasing and other relationships exist with other ineligible firms in the same or similar lines of work. SBE owner(s) shall enjoy the customary incidents of ownership and shall share in the risks and profits commensurate with their enjoyment interests, as demonstrated by an examination of the substance rather than form or arrangements that may be reflected in its ownership documents.
- B. A business that has averaged no more than \$4.0 million in annual gross receipts over the prior three year period and the principal owner(s) do not have a personal net worth in excess of \$1.32 million.

Firm and/or individuals that submit fraudulent documents/testimony may be barred from doing business with the City and/or forfeit existing contracts.

SBE certification is valid for one (1) year unless revoked.

SECTION D: SPECIAL PROVISIONS

CHIP SEALING 2020 - EAST CONTRACT NO. 8509

It is the intent of these Special Provisions to set forth the final contractual intent as to the matter involved and shall prevail over the Standard Specifications and plans whenever in conflict therewith. In order that comparisons between the Special Provisions can be readily made, the numbering system for the Special Provisions is equivalent to that of the Specifications.

Whenever in these Specifications the term "Standard Specifications" appears, it shall be taken to refer to the City of Madison Standard Specifications for Public Works Construction and Supplements thereto.

SECTION 102.11: BEST VALUE CONTRACTING

This Contract shall be considered a Best Value Contract if the Contractor's bid is equal to or greater than \$63,500 for a single trade contract; or equal to or greater than \$311,500 for a multi-trade contract pursuant to MGO 33.07(7).

ARTICLE 104 SCOPE OF WORK

The work under this contract consists street sweeping and cleaning of all loose material, vegetation and other objectionable material, the protection of inlets and castings and chip sealing. It is the Contractors responsibility to find locations to stockpile all required materials and dispose of all swept and waste material. The stockpiles may not be stored within the City of Madison's street right-of-way. **The street sweeping shall be the Contractor's responsibility. The City will no longer sweep after the Contractor's first sweeping. This WILL require multiple sweepings to clean up ALL the loose aggregate.**

NO Chip sealing shall occur on Fridays unless approved by the Engineer. All streets shall be swept by Friday night at 7 pm each week.

Any street segment labeled with an **Asterisk (*)** on the proposal pages **shall** require only the skip line pavement marking removal.

The Contractor shall be required to sweep ALL sealed streets and side streets where tracking may occur outside the limits of chip sealing. ALL loose aggregate left from the chip sealing application shall be the Contractors responsibility. This may require more than one sweeping. If sweeping becomes an issue, the Engineer may halt all sealing operations until the sweeping meets the Engineers satisfaction.

The Contractor shall supply the city with samples of the aggregate and emulsion for testing purposes prior to starting work. The Contract shall supply the material in a timely manner to allow the City to accomplish the testing before any work begins.

SECTION 104.6 DECREASED AND DELETED ITEMS

The City of Madison reserves the right to delete any street segment they deem necessary. Such deletion shall not constitute the basis for a claim for damages for anticipated profits for the work dispensed with.

SECTION 107.7 MAINTENANCE OF TRAFFIC

All traffic control shall conform to Part VI of the Federal Highways Administrations "Manual on Uniform Traffic Control Devices" (MUTCD), the State of Wisconsin Standard Facilities Development Manual (including Chapter 16 – Standard Detail Drawings) and the City of Madison Standards for sidewalk and bikeway closures.

The Contractor shall submit a schedule of work to the office of the City Traffic Engineer, a minimum of 48 hours prior to the start of work on this project.

Streets shall remain open to traffic at all times. This will require the use of properly equipped flag persons. On multi lane roadways, lane closures are permitted, using the traffic control as established by the MUTCD.

The Contractor may remove parking within the construction limits between the hours of 7:00 a.m. and 6:00 p.m. to facilitate construction on this project. Removal of parking between the hours of 6:00 p.m. and 7:00 a.m. is subject to approval City Traffic Engineering. The city will supply the contractor with the no parking signs. Please see the "Guideline for Temporary No Parking Restrictions for Construction or Special Events" contained in these special provisions.

If a street is posted with no parking signs and no work has occurred within 4 days of the posting. The Contractor **WILL** be required to remove the no parking posting, restore parking and repost the street for sealing at a later date.

The Contractor shall provide pedestrian access that is Handicap Accessible across each intersection at all times.

Access to adjacent properties shall be maintained at all times.

Peak hour restrictions shall apply for the below mentioned streets. Peak hours shall be defined as Monday through Friday between the hours of 7 A.M. and 9 A.M. and 3 P.M. to 6 P.M. Peak

The Contractor shall **only** chip seal one half of the street at a time and use arrow boards to direct traffic when Chip sealing due to bus traffic and traffic volume. The Contractor shall also have several flaggers available and on site when sealing the following streets to assist in the traffic control for the streets listed below:

AMNICON TRL
ARGOSY CT
COMMERCIAL AVE SERVICE RD
DENNETT DR
DOMINION DR
INWOOD WAY
MEADOWLARK DR
MERRYTURN RD
MILWAUKEE ST
N SPRECHER RD
N STOUGHTON RD SERVICE RD
NAKOOSA TRL
N FAIR OAKS AVE
NEPTUNE CT
NORTH STAR DR
PULLEY DR
S SPRECHER RD
S STOUGHTON RD SERVICE RD (W)
SWANTON RD
WALSH RD
WYALUSING DR

The Contractor shall maintain warning signs for "loose gravel" on ALL streets until the Contractor has swept the completed Chip Sealed Street.

SECTION 109.2 PROSECUTION OF WORK

Work shall begin only after the start work letter is received. The Contractor shall be required to limit workdays to 7:00 PM and work shall not be performed on holidays.

The contractor must consult the Engineer about the proposed schedule for the work to be done under this contract, to assure there will not be any conflicts with other city projects. Each time, work is resumed; the Contractor shall notify the Engineer at least seventy-two (72) hours in advance of beginning work. During periods of work, the Contractor shall provide the Engineer a schedule of the work such that the Engineer is able to inspect the daily progress of the contract, and allow the Engineer to alter the contractors schedule to avoid potential conflicts with other city projects.

SECTION 109.7 TIME OF COMPLETION

The Contractor shall complete all work specified in this contract on or before **JULY 31, 2020**.

SECTION 109.9 LIQUIDATED DAMAGES

Liquidated damages shall be assessed in accordance with the City of Madison standard specifications.

Additional liquidated damages shall be assessed to the Contractor if the inlet protection is not removed within 7 days of the final sweeping. For every day after the 7 days the inlet protection is not removed the Contractor shall be assessed \$100 in liquidated damages per inlet per day that the inlet protection is not removed.

Additional liquidated damages shall be assessed to the Contractor for each street that is not swept within 2 days (48 hours) of chip sealing the street. For every day after the 2 days (48 hours) each street is not swept in accordance with these specifications, the Contractor shall be assessed \$250 in liquidated damages per street per day.

BID ITEM 21041 INLET PROTECTION, TYPE D – COMPLETE (UNDISTRIBUTED)

DESCRIPTION

This item is undistributed and may or may not be used. It is intended for use at low points of the road when the chip sealing may occur with rain in the forecast. The Engineer will notify the Contractor where and when; Type D inlet protection should be installed.

Work under this item shall include all work, materials, labor and incidentals necessary for installing, maintaining, and removing the Inlet Protection Type D device.

The Contractor shall be responsible at a minimum to inspect weekly and within 24 hours after every precipitation event that produces 0.5 inches of rain or more during a 24-hour period. The Contractor shall remove sediment deposits, dispose of sediment, and restore device to its original dimension after accumulation of sediment is between one-third (1/3) to one-half (1/2) the design depth of the device. The contractor shall replace a non-operating device with a new device that will be considered incidental. The Contractor shall take care to ensure sediment does not fall within the inlet. If sediment does fall within the inlet, the Contractor shall be responsible for removing and disposing of the sediment.

METHOD OF MEASUREMENT

Inlet Protection, Type D - Complete shall be measured as each acceptably completed and approved by the Construction Engineer.

BASIS OF PAYMENT

Inlet Protection, Type D - Complete shall be measured as described above which shall be full compensation for all work, materials, and incidentals to complete the work as described above.

SECTION 408.1 MATERIALS FOR PAVEMENT CHIP SEALING

The aggregate for the Chip Seal shall be Class A, Granite, and shall be grey in color or an approved equivalent. The gradation for the material shall conform to the following requirements:

SIEVE SIZE	PERCENT(%) PASSING BY WEIGHT	TOLERANCE %
1/2 inch(12.5 mm)	100	----
3/8 inch(9.5 mm)	100	± 5
1/4 inch(6.3 mm)	100	± 7
No. 4(4.75 mm)	0 - 100	± 7
No. 8(2.36 mm)	0 - 40	± 4
No.16(1.18 mm)	0 - 10	± 4
No. 50(300 µm)	0 - 5	± 4
No. 100(150 µm)	----	± 4
No. 200(75 µm)	0.0 - 1.0	----

Chip Sealing and Seal Coat are considered to be one and the same for these special provisions. The Chip Seal shall conform to Section 475 "Seal Coat" of the "Standard Specifications for Highway and Structure Construction" prepared by the State of Wisconsin Department of Transportation and these special provisions herein set forth shall govern this construction.

The asphaltic material for the Chip Seal shall be CRS-2P; Polymer modified, and be applied at a rate of 0.30-0.32 gallons per square yard. This asphaltic material shall be rapid set emulsion that has elastic properties and shall comply with AASHTO M316.

The temperature of the Asphaltic Emulsion at the time of application shall not be less than 150 degrees Fahrenheit or more than 180 degrees Fahrenheit.

The aggregate for the Chip Seal shall be Class A, Granite, and shall be grey in color or an approved equivalent. The Gradation for the material shall conform to the following requirements:

The Contractor will be required to supply a sample to the Engineer prior to the start of work. The Contractor shall also submit written verification from their Supplier that the asphalt emulsion and aggregate properly bond. Should there be any discrepancies in the field; the Contractor shall be responsible for all costs associated with repairs. The application rates for the screenings and Asphaltic Emulsion shall be within the range specified in the following table.

	SCREENING (LB/S.Y.)	ASPHALTIC EMULSION (GAL. /S.Y.)
Single Chip Seal	20 TO 22	0.30-0.32

SECTION 408.2 PERSONNEL

The Contractor's personnel shall be experienced in Chip Sealing work and shall be knowledgeable regarding the material and equipment to be used for Chip Sealing.

SECTION 408.3 EQUIPMENT

The Contractor shall furnish all equipment necessary, but not be limited to the equipment specified in Section 475.3.2 of the WISDOT Standard Specifications.

The second paragraph of the WISDOT Standard Specifications, Section 475.3.5 "Applying and Rolling Seal Coat Aggregate" is amended to read as follows:

The Contractor shall furnish a minimum of two (2) pneumatic-tired rollers.

The initial rolling shall consist of one (1) complete coverage performed with a pneumatic-tired roller and shall begin immediately behind the spreader. Binder and screenings shall not be spread more than 500 feet ahead of completion of the initial rolling operations. Secondary rolling shall begin immediately after completion of the initial rolling. The amount of secondary rolling shall be sufficient to adequately seat the screenings and in no case shall be less than two (2) complete coverages.

The Contractor shall sweep the completed Chip Sealed streets within FORTY-EIGHT (48) hours after the second rolling or after the Chip Sealing is set whichever is sooner.

SECTION 408.4 PREPARATION OF THE SURFACE AND PROTECTION

Immediately before applying the Asphaltic Emulsion, the Contractor shall be responsible for removing all loose material, silt, clay, vegetation in the street and edge of gutter and other objectionable materials from the street with a power broom, street sweeper, edger or other approved method. **The Contractor shall install reflective tabs on the streets that have pavement marking prior to sealing streets. The tabs shall be installed on the existing pavement marking to notify the traffic of the lane delineations after the street has been sealed.**

Prior to Chip Sealing the Contractor shall protect all inlets contained within the Chip Sealing area and downstream inlets in accordance with Article 210 – EROSION CONTROL of the City of Madison's Standard Specifications and the WDNR Conservation Practice Standards, or as determined necessary by the Construction Engineer. WDNR Conservation Practice Standards referenced in these Standard Specifications are available on-line at http://dnr.wi.gov/topic/stormwater/standards/const_standards.html. Inlet protection shall be installed per WDNR Conservation Practice 1060 - Storm Drain Inlet Protection TYPE C for Construction Sites available on-line at http://dnr.wi.gov/topic/stormWater/documents/StormDrainInletProtectionConstructionSites_1060.pdf

It shall be the Contractors responsibility to locate and protect all utility castings including but not limited to sewer access structures, water valves, inlets, and catchbasins within the street or streets to be chip sealed prior to starting work and protect these castings so that **ABSOLUTELY NO ASPHALTIC EMULSION** will be applied. If castings are covered by chip sealing the Contractor will be responsible to clean and or replace the all the castings at their own expense, as required by the City Engineer. No work shall begin until all utility castings are protected. No work shall begin until all Traffic Control is in place as required in Section 107.7.

All inlet protection shall remain in place until the streets are swept to the satisfaction of the Engineer. Please note that BID ITEM 21041 INLET PROTECTION, TYPE D - COMPLETE is undistributed and may or may not be used. All other inlet protection is considered incidental to lump sum bid of chip sealing.

SECTION 408.5 METHOD OF MEASUREMENT

The Contractor shall bid each Street segment in the contract individually; based on the price to properly Chip Seal the street segment according to the conditions provided in this contract. Each segment will be bid as a "lump sum" price. It is the Contractors responsibility to review each street segment and verify the area to be chip sealed.

SECTION 408.6 BASIS OF PAYMENT

Chip Sealing will be paid for at the Contractors bid price per street segment. Which price shall be full compensation for furnishing; heating, unloading, hauling, and for applying the Chip Sealing material; for the cleaning of the streets, installing reflective tabs, applying the Asphalt Emulsion and Chips, Rolling,

street sweeping; for locating stockpile locations and disposal of all waste material, for the protection of inlets and utility casting; and for all labor, tools, equipment, and incidental necessary to complete the work as provided in the contract.

ARTICLE 608 PAVEMENT MARKINGS

The streets listed below shall require REMOVAL OF ONLY THE SKIP LINES. Removal of the lines shall be measured by the linear foot removed.

COMMERCIAL AVE SERVICE RD
MEADOWLARK DR
MILWAUKEE ST
N FAIR OAKS AVE
N WALBRIDGE AVE
NAKOOSA TRL
NORTH STAR DR
S SPRECHER RD
S STOUGHTON RD SERVICE RD (W)
S THOMPSON DR
SWANTON RD
WALSH RD
WITTWER RD

Epoxy pavement markings will be required as described in the pavement marking plans included in this contract.



**Madison Police Department
Parking Enforcement**
Phone: (608) 266-4622
www.cityofmadison.com/police



City of Madison Parking Utility
215 Martin Luther King Blvd, Suite 100
Madison, WI 53703
Phone: (608) 266-4761
www.cityofmadison.com/parking

Posting for Temporary Parking Restrictions

Instructions

1. Partial & full block postings: signs every 50-60 feet.
Single address postings: signs at the boundaries of your property.
2. Signs **must** be 3-4 feet off the ground, facing oncoming traffic, and perpendicular to the street.
3. Signs should be placed within 3 feet of the curb.
4. **Call (608) 266-4622** (Monday - Friday before 3pm) for signs to be checked.
Signs must be approved 48 hours in advance before enforcement can be taken.
5. Changes to your No Parking signs (dates) **must be updated through Parking Utility** and the signs will need to be rechecked.
6. You are responsible for removing your temporary posting signs and uncovering any signs that were covered.

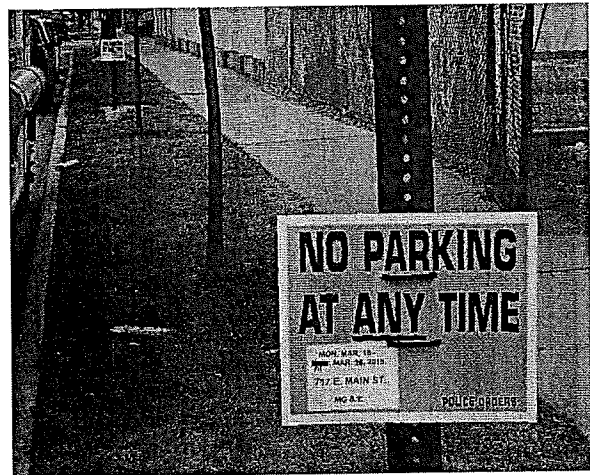
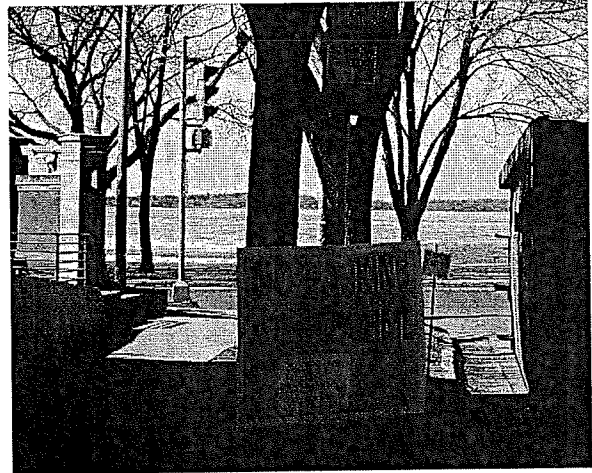

Things to Remember

1. Signs may not be attached to trees or electrical poles & cannot be blocked by trees, bushes, poles, etc.
2. **Signs must be securely fastened** to the stake & secure in the ground.

Who to Call for Enforcement

If a vehicle is parked in your approved posted area, **contact dispatch at (608) 266-4275.**



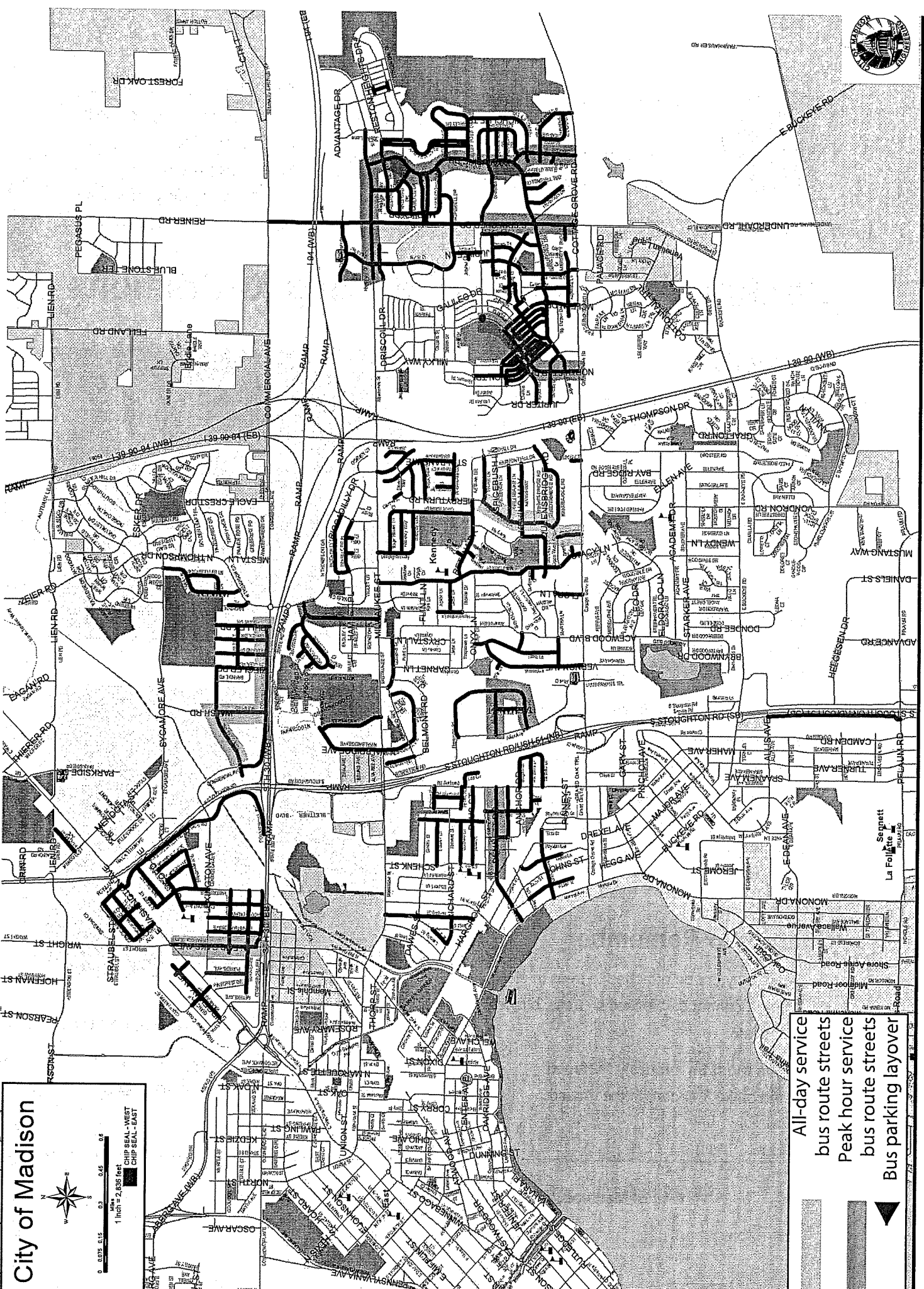

City of Madison

0 0.05 0.1 0.15 0.2 0.25 0.3 0.4 0.5 0.6

1 inch = 2,435 feet

CHIP SEAL - WEST
CHIP SEAL - EAST

- All-day service
- bus route streets
- Peak hour service
- bus route streets
- Bus parking layover

City of Madison

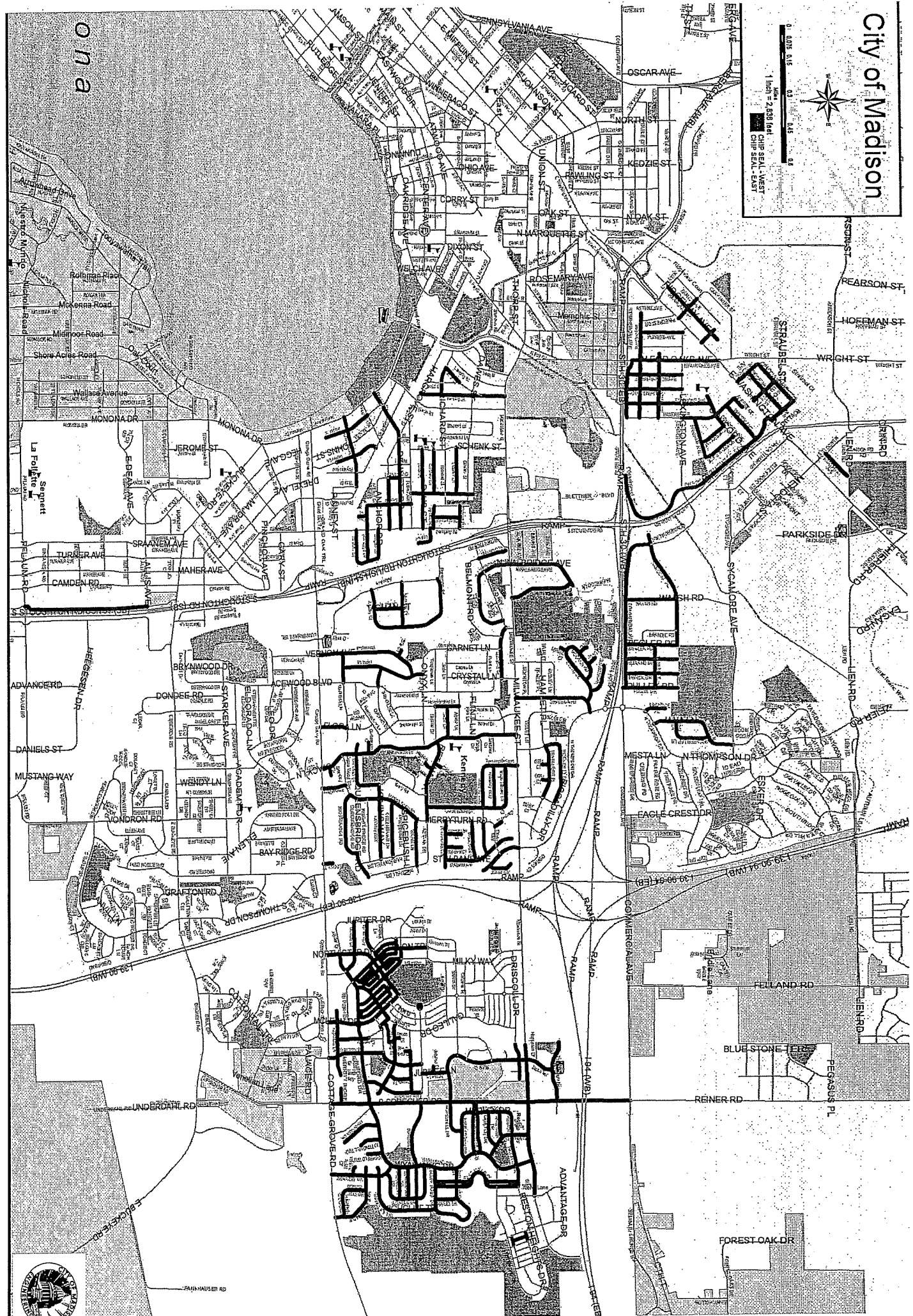
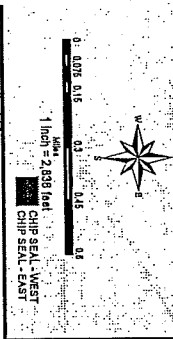

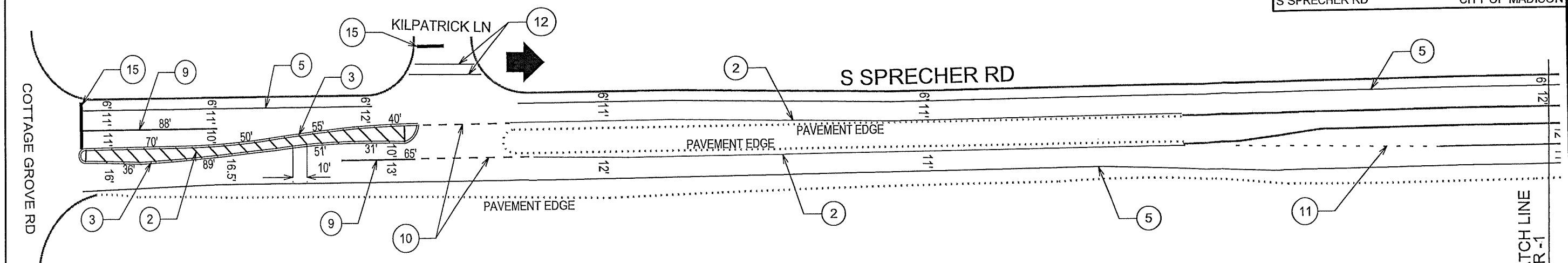

Callout	Bid Item	Description
1	60800	Pavement Marking Epoxy, 4-Inch, Solid White
2	60800	Pavement Marking Epoxy, 4-Inch, Solid Yellow
3	60800	Pavement Marking Epoxy, 4-Inch Yellow Skips, (10' Line, 30' Gap)
4	60801	Pavement Marking Epoxy, 4-Inch Double Yellow
5	60802	Pavement Marking Epoxy, 6-Inch Solid White
6	60802	Pavement Marking Epoxy, 6-Inch White Skips, (10' Line, 30' Gap)
7	60802	Pavement Marking Epoxy, 6-Inch Yellow Skips (10' Line, 30' Gap)
8	60802	Pavement Marking Epoxy, 6-Inch White Skips, (2' Line, 6' Gap)
9	60803	Pavement Marking Epoxy, 8-Inch Solid White
10	60803	Pavement Marking Epoxy, 8-Inch White Skips, (5' Line, 5' Gap)
11	60803	Pavement Marking Epoxy, 8-Inch White Skips, (2' Line, 6' Gap)
12	60812	Pavement Marking Epoxy, 6-Inch White, Crosswalk
13	60814	Pavement Marking Epoxy, 12-Inch White, Crosswalk
14	60816	Pavement Marking Epoxy, Continental 18-Inch White, Crosswalk
15	60818	Pavement Marking Epoxy, 24-Inch White, Stop Line
16	60823	Pavement Marking Epoxy, Symbol, Bike Lane
17	60829	Pavement Marking Epoxy, Symbol, Left Arrow
18	60830	Pavement Marking Epoxy, Symbol, Right Arrow
19	60834	Pavement Marking Epoxy, Word, "ONLY"

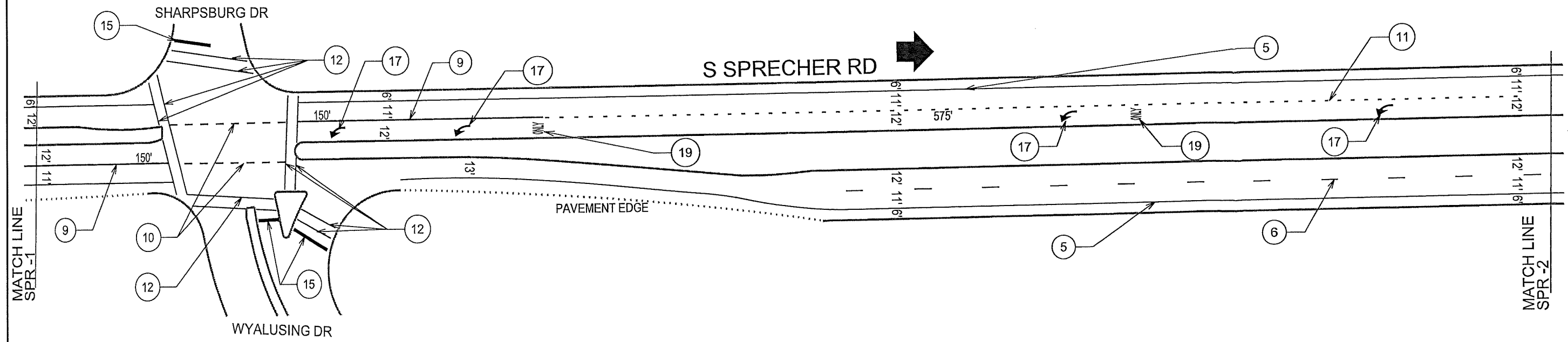

PLOT SCALE:
 PLOT NAME:
 REV. DATE:
 ORIGINATOR: CITY OF MADISON, TRAFFIC ENG. DIV.

PLOT SCALE:

PLOT NAME:

REV. DATE:

ORIGINATOR: CITY OF MADISON, TRAFFIC ENG. DIV.

FILE NAME: \$\$...designfile...\$\$

DATE: \$\$...plottingdate...\$\$

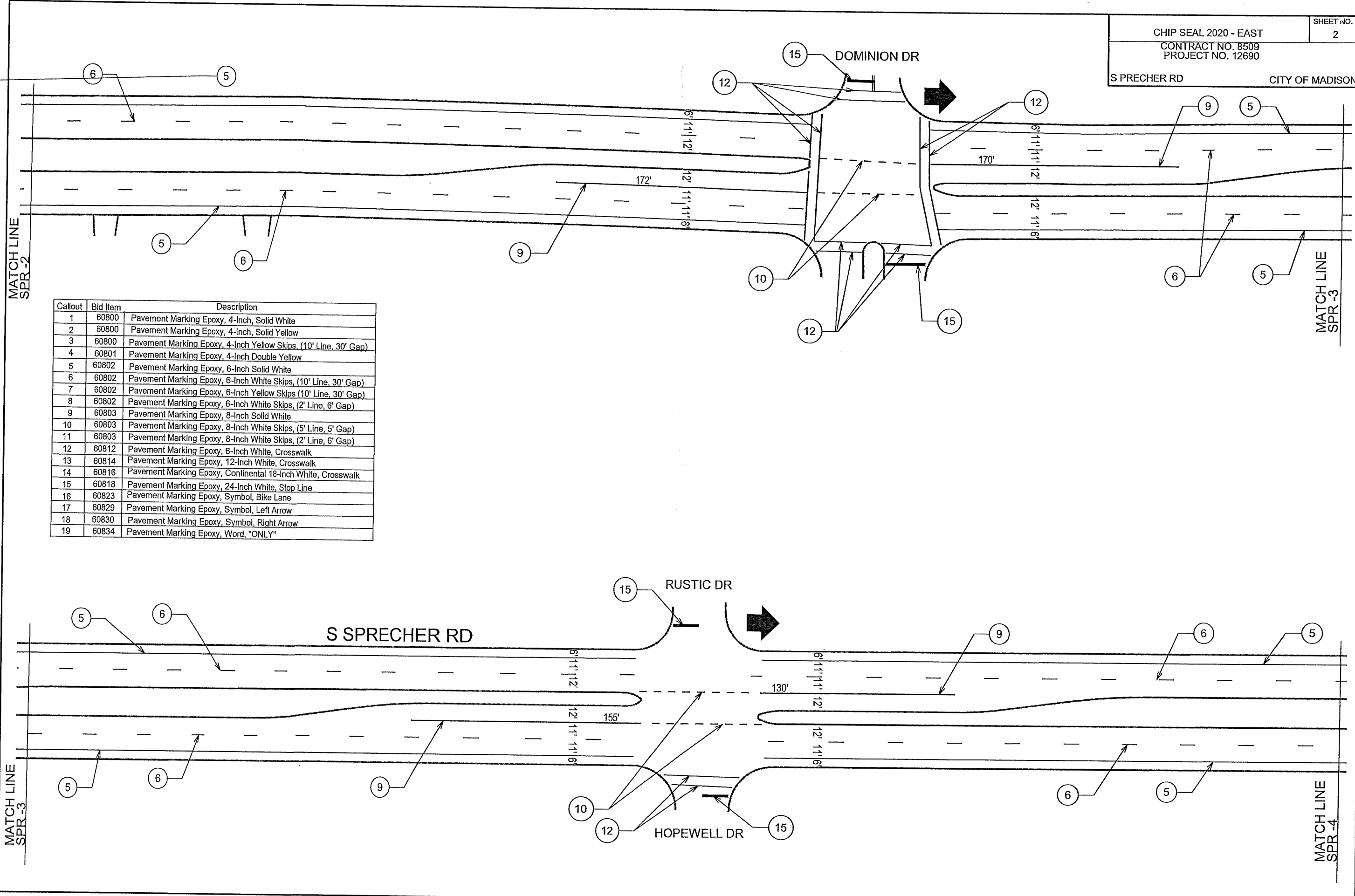

Callout	Bid Item	Description
1	60800	Pavement Marking Epoxy, 4-Inch, Solid White
2	60800	Pavement Marking Epoxy, 4-Inch, Solid Yellow
3	60800	Pavement Marking Epoxy, 4-Inch Yellow Skips, (10' Line, 30' Gap)
4	60801	Pavement Marking Epoxy, 4-Inch Double Yellow
5	60802	Pavement Marking Epoxy, 6-Inch Solid White
6	60802	Pavement Marking Epoxy, 6-Inch White Skips, (10' Line, 30' Gap)
7	60802	Pavement Marking Epoxy, 6-Inch Yellow Skips (10' Line, 30' Gap)
8	60802	Pavement Marking Epoxy, 6-Inch White Skips, (2' Line, 6' Gap)
9	60803	Pavement Marking Epoxy, 8-Inch Solid White
10	60803	Pavement Marking Epoxy, 8-Inch White Skips, (5' Line, 5' Gap)
11	60803	Pavement Marking Epoxy, 8-Inch White Skips, (2' Line, 6' Gap)
12	60812	Pavement Marking Epoxy, 6-Inch White, Crosswalk
13	60814	Pavement Marking Epoxy, 12-Inch White, Crosswalk
14	60816	Pavement Marking Epoxy, Continental 18-Inch White, Crosswalk
15	60818	Pavement Marking Epoxy, 24-Inch White, Stop Line
16	60823	Pavement Marking Epoxy, Symbol, Bike Lane
17	60829	Pavement Marking Epoxy, Symbol, Left Arrow
18	60830	Pavement Marking Epoxy, Symbol, Right Arrow
19	60834	Pavement Marking Epoxy, Word, "ONLY"

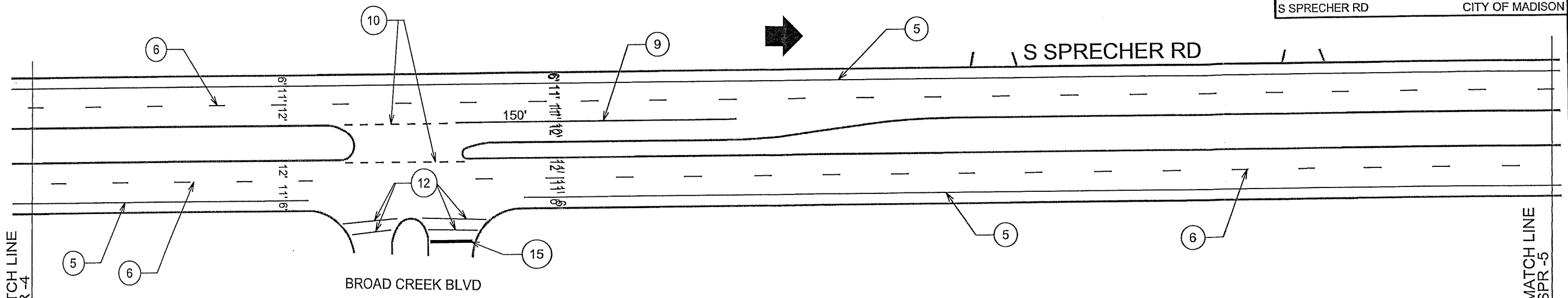

Callout	Bid Item	Description
1	60800	Pavement Marking Epoxy, 4-Inch, Solid White
2	60800	Pavement Marking Epoxy, 4-Inch, Solid Yellow
3	60800	Pavement Marking Epoxy, 4-Inch Yellow Skips, (10' Line, 30' Gap)
4	60801	Pavement Marking Epoxy, 4-Inch Double Yellow
5	60802	Pavement Marking Epoxy, 6-Inch Solid White
6	60802	Pavement Marking Epoxy, 6-Inch White Skips, (10' Line, 30' Gap)
7	60802	Pavement Marking Epoxy, 6-Inch Yellow Skips (10' Line, 30' Gap)
8	60802	Pavement Marking Epoxy, 6-Inch White Skips, (2' Line, 6' Gap)
9	60803	Pavement Marking Epoxy, 8-Inch Solid White
10	60803	Pavement Marking Epoxy, 8-Inch White Skips, (5' Line, 5' Gap)
11	60803	Pavement Marking Epoxy, 8-Inch White Skips, (2' Line, 6' Gap)
12	60812	Pavement Marking Epoxy, 6-Inch White, Crosswalk
13	60814	Pavement Marking Epoxy, 12-Inch White, Crosswalk
14	60816	Pavement Marking Epoxy, Continental 18-Inch White, Crosswalk
15	60818	Pavement Marking Epoxy, 24-Inch White, Stop Line
16	60823	Pavement Marking Epoxy, Symbol, Bike Lane
17	60829	Pavement Marking Epoxy, Symbol, Left Arrow
18	60830	Pavement Marking Epoxy, Symbol, Right Arrow
19	60834	Pavement Marking Epoxy, Word, "ONLY"

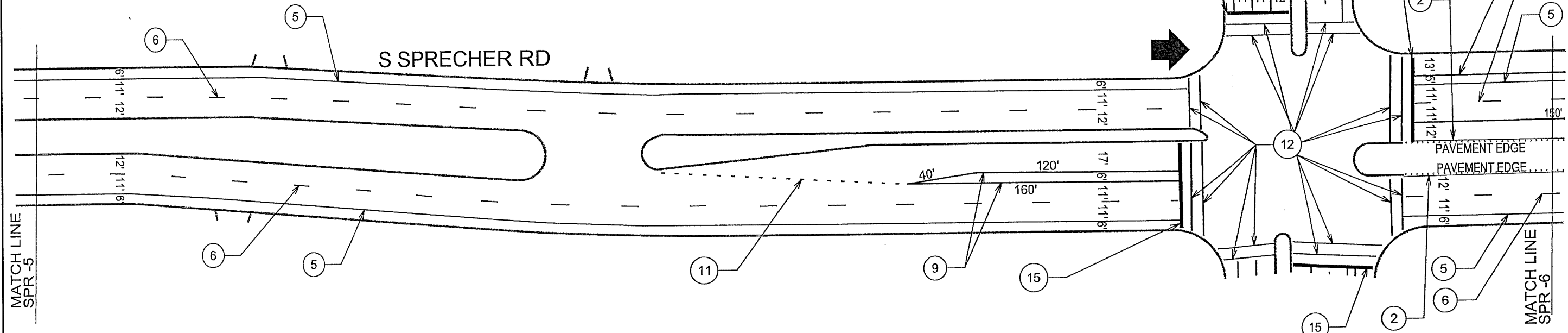

SEE ALSO PAGE 5
 MILWAUKEE ST

PLOT SCALE:

PLOT NAME:

REV. DATE:

ORIGINATOR: CITY OF MADISON, TRAFFIC ENG. DIV.

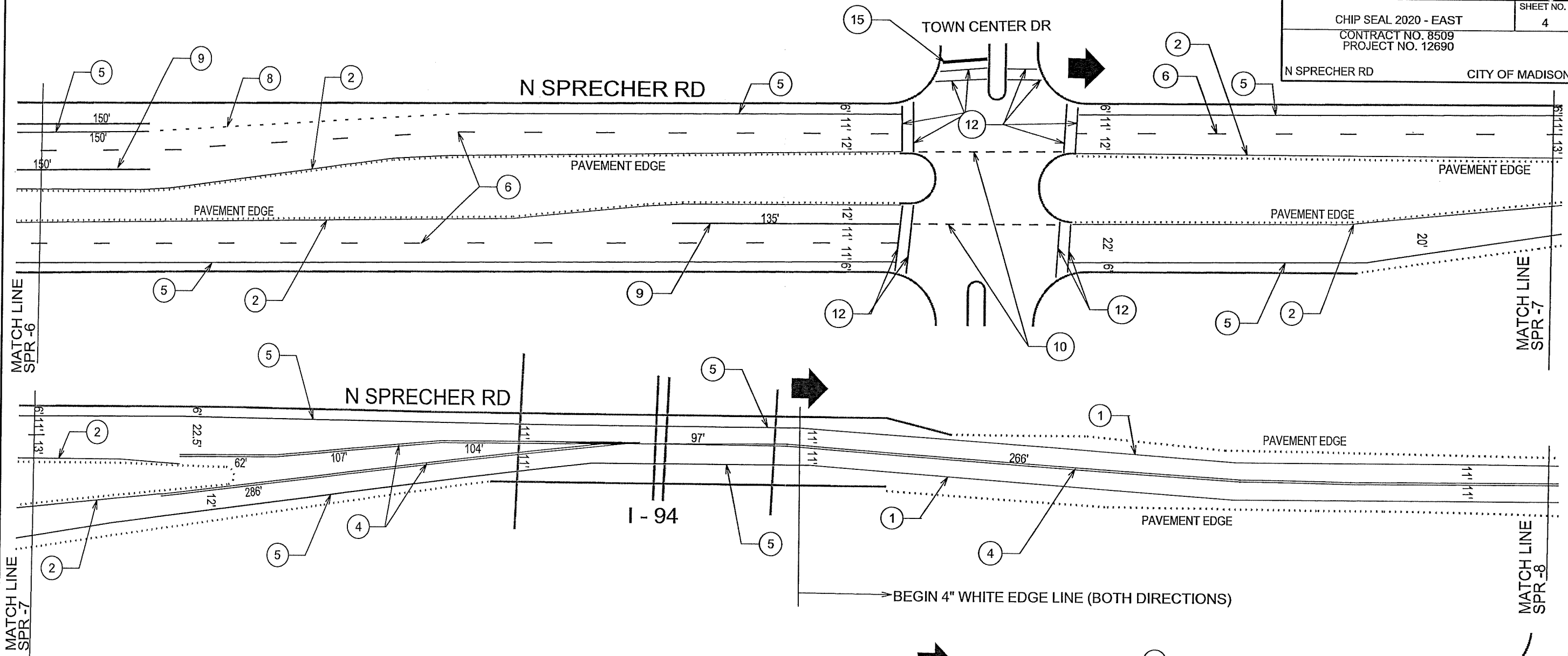

Callout	Bid Item	Description
1	60800	Pavement Marking Epoxy, 4-Inch, Solid White
2	60800	Pavement Marking Epoxy, 4-Inch, Solid Yellow
3	60800	Pavement Marking Epoxy, 4-Inch Yellow Skips, (10' Line, 30' Gap)
4	60801	Pavement Marking Epoxy, 4-Inch Double Yellow
5	60802	Pavement Marking Epoxy, 6-Inch Solid White
6	60802	Pavement Marking Epoxy, 6-Inch White Skips, (10' Line, 30' Gap)
7	60802	Pavement Marking Epoxy, 6-Inch Yellow Skips (10' Line, 30' Gap)
8	60802	Pavement Marking Epoxy, 6-Inch White Skips, (2' Line, 6' Gap)
9	60803	Pavement Marking Epoxy, 8-Inch Solid White
10	60803	Pavement Marking Epoxy, 8-Inch White Skips, (5' Line, 5' Gap)
11	60803	Pavement Marking Epoxy, 8-Inch White Skips, (2' Line, 6' Gap)
12	60812	Pavement Marking Epoxy, 6-Inch White, Crosswalk
13	60814	Pavement Marking Epoxy, 12-Inch White, Crosswalk
14	60816	Pavement Marking Epoxy, Continental 18-Inch White, Crosswalk
15	60818	Pavement Marking Epoxy, 24-Inch White, Stop Line
16	60823	Pavement Marking Epoxy, Symbol, Bike Lane
17	60829	Pavement Marking Epoxy, Symbol, Left Arrow
18	60830	Pavement Marking Epoxy, Symbol, Right Arrow
19	60834	Pavement Marking Epoxy, Word, "ONLY"

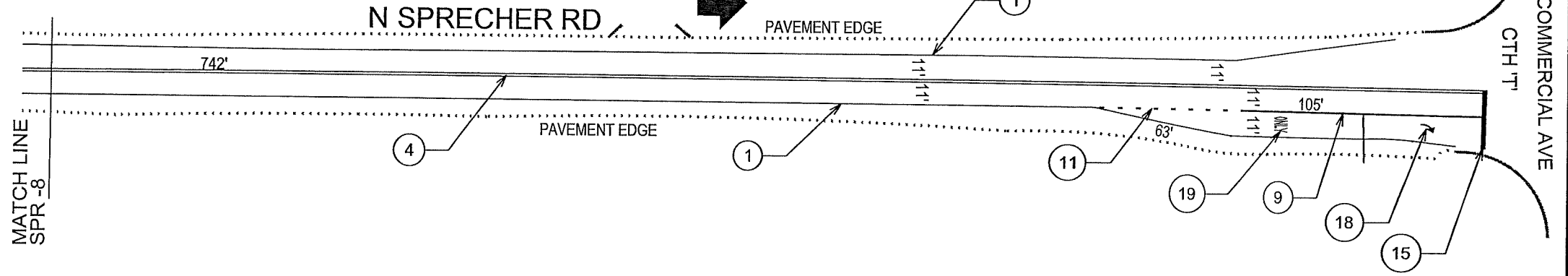

PLOT SCALE:

PLOT NAME:

REV. DATE:

ORIGINATOR: CITY OF MADISON, TRAFFIC ENG. DIV.

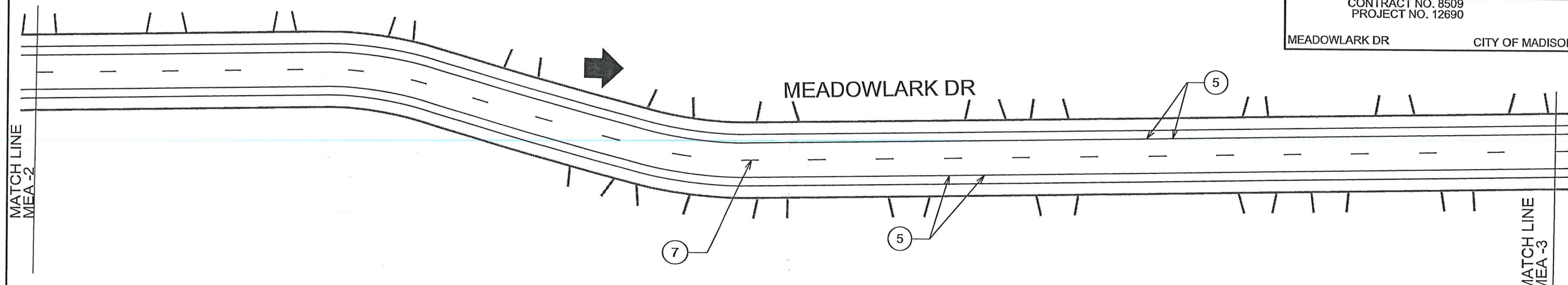

Callout	Bid Item	Description
1	60800	Pavement Marking Epoxy, 4-Inch, Solid White
2	60800	Pavement Marking Epoxy, 4-Inch, Solid Yellow
3	60800	Pavement Marking Epoxy, 4-Inch Yellow Skips, (10' Line, 30' Gap)
4	60801	Pavement Marking Epoxy, 4-Inch Double Yellow
5	60802	Pavement Marking Epoxy, 6-Inch Solid White
6	60802	Pavement Marking Epoxy, 6-Inch White Skips, (10' Line, 30' Gap)
7	60802	Pavement Marking Epoxy, 6-Inch Yellow Skips (10' Line, 30' Gap)
8	60802	Pavement Marking Epoxy, 6-Inch White Skips, (2' Line, 6' Gap)
9	60803	Pavement Marking Epoxy, 8-Inch Solid White
10	60803	Pavement Marking Epoxy, 8-Inch White Skips, (5' Line, 5' Gap)
11	60803	Pavement Marking Epoxy, 8-Inch White Skips, (2' Line, 6' Gap)
12	60812	Pavement Marking Epoxy, 6-Inch White, Crosswalk
13	60814	Pavement Marking Epoxy, 12-Inch White, Crosswalk
14	60816	Pavement Marking Epoxy, Continental 18-Inch White, Crosswalk
15	60818	Pavement Marking Epoxy, 24-Inch White, Stop Line
16	60823	Pavement Marking Epoxy, Symbol, Bike Lane
17	60829	Pavement Marking Epoxy, Symbol, Left Arrow
18	60830	Pavement Marking Epoxy, Symbol, Right Arrow
19	60834	Pavement Marking Epoxy, Word, "ONLY"

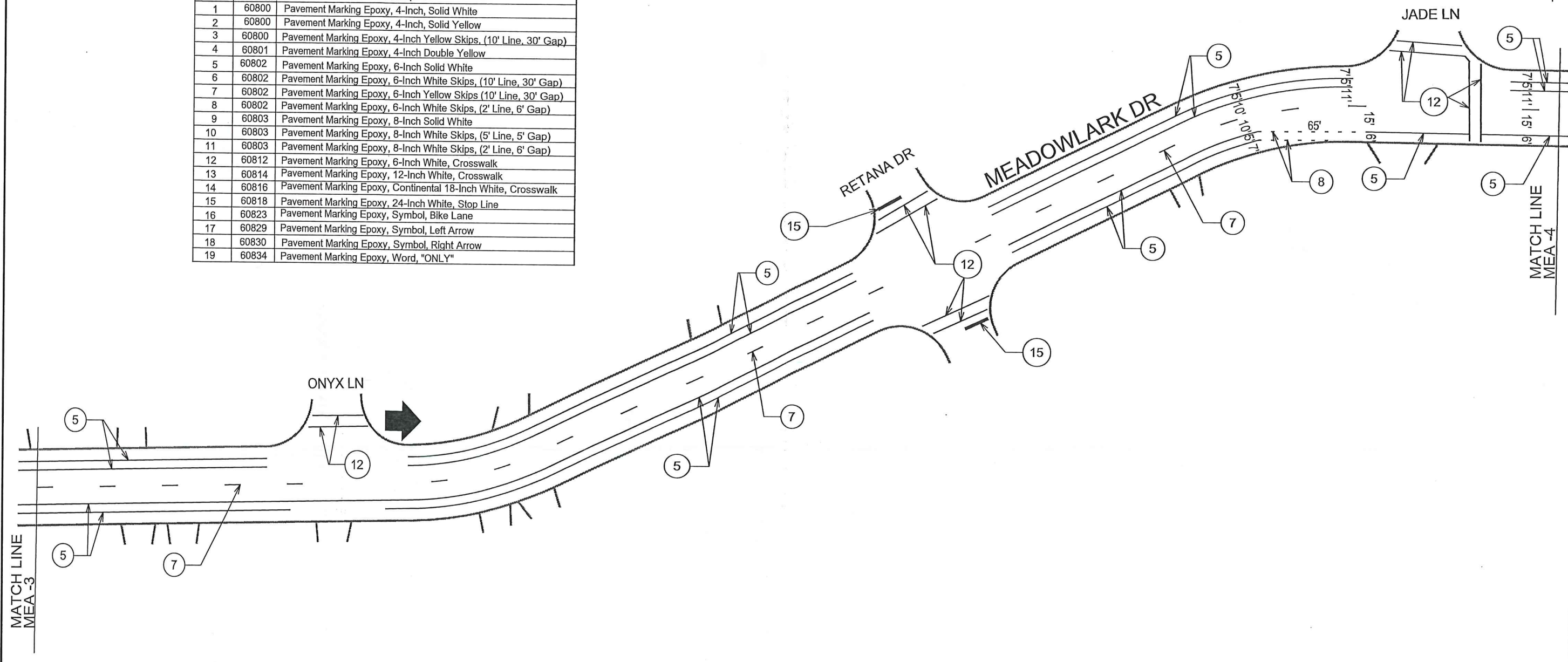

PLOT SCALE:

PLOT NAME:

REV. DATE:

ORIGINATOR: CITY OF MADISON, TRAFFIC ENG. DIV.

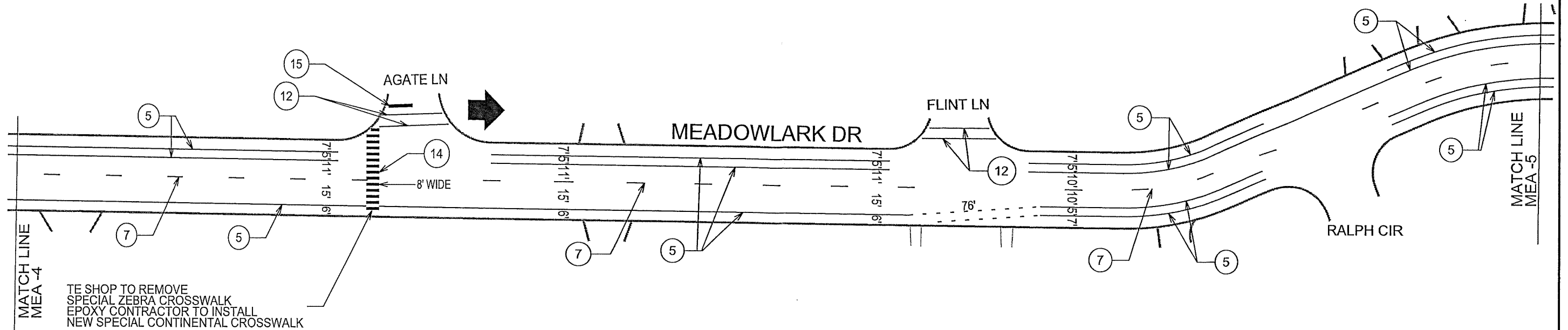

Callout	Bid Item	Description
1	60800	Pavement Marking Epoxy, 4-Inch, Solid White
2	60800	Pavement Marking Epoxy, 4-Inch, Solid Yellow
3	60800	Pavement Marking Epoxy, 4-Inch Yellow Skips, (10' Line, 30' Gap)
4	60801	Pavement Marking Epoxy, 4-Inch Double Yellow
5	60802	Pavement Marking Epoxy, 6-Inch Solid White
6	60802	Pavement Marking Epoxy, 6-Inch White Skips, (10' Line, 30' Gap)
7	60802	Pavement Marking Epoxy, 6-Inch Yellow Skips (10' Line, 30' Gap)
8	60802	Pavement Marking Epoxy, 6-Inch White Skips, (2' Line, 6' Gap)
9	60803	Pavement Marking Epoxy, 8-Inch Solid White
10	60803	Pavement Marking Epoxy, 8-Inch White Skips, (5' Line, 5' Gap)
11	60803	Pavement Marking Epoxy, 8-Inch White Skips, (2' Line, 6' Gap)
12	60812	Pavement Marking Epoxy, 6-Inch White, Crosswalk
13	60814	Pavement Marking Epoxy, 12-Inch White, Crosswalk
14	60816	Pavement Marking Epoxy, Continental 18-Inch White, Crosswalk
15	60818	Pavement Marking Epoxy, 24-Inch White, Stop Line
16	60823	Pavement Marking Epoxy, Symbol, Bike Lane
17	60829	Pavement Marking Epoxy, Symbol, Left Arrow
18	60830	Pavement Marking Epoxy, Symbol, Right Arrow
19	60834	Pavement Marking Epoxy, Word, "ONLY"

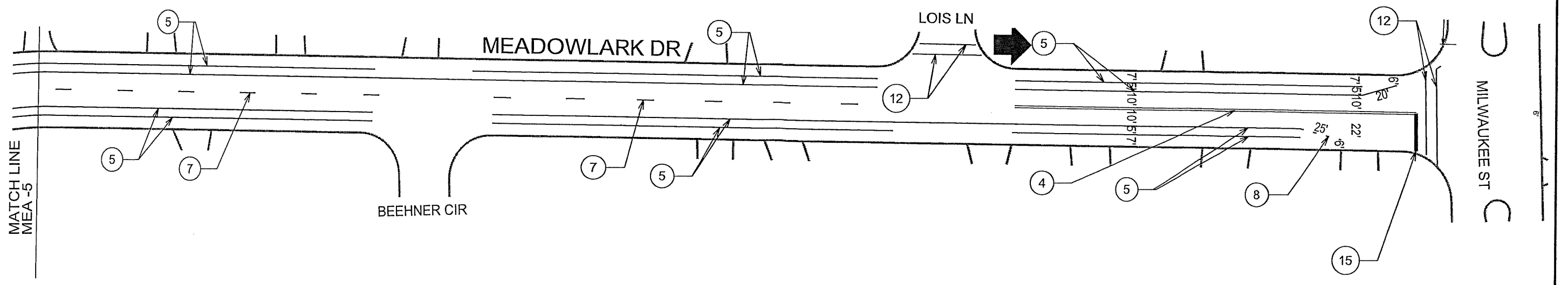

PLOT SCALE:

PLOT NAME:

REV. DATE:

ORIGINATOR: CITY OF MADISON, TRAFFIC ENG. DIV.

SECTION E: BIDDERS ACKNOWLEDGEMENT

CHIP SEALING 2020 - EAST
CONTRACT NO. 8509

Bidder must state a Unit Price and Total Bid for each item. The Total Bid for each item must be the product of quantity, by Unit Price. The Grand Total must be the sum of the Total Bids for the various items. In case of multiplication errors or addition errors, the Grand Total with corrected multiplication and/or addition shall determine the Grand Total bid for each contract. The Unit Price and Total Bid must be entered numerically in the spaces provided. All words and numbers shall be written in ink.

1. The undersigned having familiarized himself/herself with the Contract documents, including Advertisement for Bids, Instructions to Bidders, Form of Proposal, City of Madison Standard Specifications for Public Works Construction - 2020 Edition thereto, Form of Agreement, Form of Bond, and Addenda issued and attached to the plans and specifications on file in the office of the City Engineer, hereby proposes to provide and furnish all the labor, materials, tools, and expendable equipment necessary to perform and complete in a workmanlike manner the specified construction on this project for the City of Madison; all in accordance with the plans and specifications as prepared by the City Engineer, including Addenda Nos. _____ through _____ to the Contract, at the prices for said work as contained in this proposal. (Electronic bids submittals shall acknowledge addendum under Section E and shall not acknowledge here)
2. If awarded the Contract, we will initiate action within seven (7) days after notification or in accordance with the date specified in the contract to begin work and will proceed with diligence to bring the project to full completion within the number of work days allowed in the Contract or by the calendar date stated in the Contract.
3. The undersigned Bidder or Contractor certifies that he/she is not a party to any contract, combination in form of trust or otherwise, or conspiracy in restraint of trade or commerce or any other violation of the anti-trust laws of the State of Wisconsin or of the United States, with respect to this bid or contract or otherwise.
4. I hereby certify that I have met the Bid Bond Requirements as specified in Section 102.5. (IF BID BOND IS USED, IT SHALL BE SUBMITTED ON THE FORMS PROVIDED BY THE CITY. FAILURE TO DO SO MAY RESULT IN REJECTION OF THE BID).
5. I hereby certify that all statements herein are made on behalf of Scott Construction, Inc. (name of corporation, partnership, or person submitting bid) a corporation organized and existing under the laws of the State of Wisconsin a partnership consisting of _____; an individual trading as _____; of the City of _____ State of _____; that I have examined and carefully prepared this Proposal, from the plans and specifications and have checked the same in detail before submitting this Proposal; that I have fully authority to make such statements and submit this Proposal in (its, their) behalf, and that the said statements are true and correct.

SIGNATURE

Vice President

TITLE, IF ANY

Sworn and subscribed to before me this
19th day of March, 2020.

Caroline M. Haswell
(Notary Public or other officer authorized to administer oaths)

My Commission Expires 6/19/23

Bidders shall not add any conditions or qualifying statements to this Proposal.

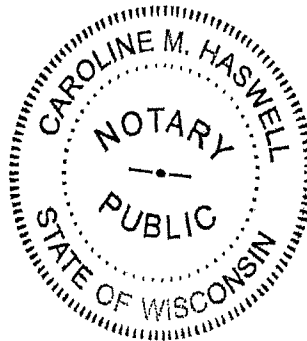

Contract 8509 – Scott Construction Inc.

Section F: Best Value Contracting (BVC)

This section is a required document for the bid to be considered complete. There are two methods for completing the Best Value Contracting (BVC) form. Method one: The form can be filled out online and submitted to this site to be included with your electronic bid. Method two: The form can be downloaded from the site and submitted by hand to the City of Madison.

Method of Submittal for BVC (click in box below to choose) *

I will submit Bid Express fillable online form (BVC).

Best Value Contracting

1. The Contractor shall indicate the non-apprenticeable trades used on this contract.

Scott Construction, Inc.

P.O. Box 340

Lake Delton, WI 53940

2. Madison General Ordinance (M.G.O.), 33.07(7), does provide for some exemptions from the active apprentice requirement. Apprenticeable trades are those trades considered apprenticeable by the State of Wisconsin. Please check applicable box if you are seeking an exemption.

- Contractor has a total skilled workforce of four or less individuals in all apprenticeable trades combined.
- No available trade training program; The Contractor has been rejected by the only available trade training program, or there is no trade training program within 90 miles.
- Contractor is not using an apprentice due to having a journey worker on layoff status, provided the journey worker was employed by the contractor in the past six months.
- First time contractor on City of Madison Public Works contract requests a onetime exemption but intends to comply on all future contracts and is taking steps typical of a "good faith" effort.
- Contractor has been in business less than one year.
- Contractor doesn't have enough journeyman trade workers to qualify for a trade training program in that respective trade.
- An exemption is granted in accordance with a time period of a "Documented Depression" as defined by the State of Wisconsin.

3. The Contractor shall indicate on the following section which apprenticeable trades are to be used on this contract. Compliance with active apprenticeship, to the extent required by M.G.O. 33.07(7), shall be satisfied by documentation from an applicable trade training body; an apprenticeship contract with the Wisconsin Department of Workforce Development or a similar

agency in another state; or the U.S Department of Labor. This documentation is required prior to the Contractor beginning work on the project site.

The Contractor has reviewed the list and shall not use any apprenticeable trades on this project.

LIST APPRENTICABLE TRADES (check all that apply to your work to be performed on this contract)

- BRICKLAYER
- CARPENTER
- CEMENT MASON / CONCRETE FINISHER
- CEMENT MASON (HEAVY HIGHWAY)
- CONSTRUCTION CRAFT LABORER
- DATA COMMUNICATION INSTALLER
- ELECTRICIAN
- ENVIRONMENTAL SYSTEMS TECHNICIAN / HVAC SERVICE TECH/HVAC INSTALL / SERVICE
- GLAZIER
- HEAVY EQUIPMENT OPERATOR / OPERATING ENGINEER
- INSULATION WORKER (HEAT and FROST)
- IRON WORKER
- IRON WORKER (ASSEMBLER, METAL BLDGS)
- PAINTER and DECORATOR
- PLASTERER
- PLUMBER
- RESIDENTIAL ELECTRICIAN
- ROOFER and WATER PROOFER
- SHEET METAL WORKER
- SPRINKLER FITTER
- STEAMFITTER
- STEAMFITTER (REFRIGERATION)
- STEAMFITTER (SERVICE)
- TAPER and FINISHER
- TELECOMMUNICATIONS (VOICE, DATA and VIDEO) INSTALLER-TECHNICIAN
- TILE SETTER

CHIP SEALING 2020 - EAST
CONTRACT NO. 8509

Small Business Enterprise Compliance Report

This information may be submitted electronically through
Bid Express or submitted with bid in sealed envelope.

Cover Sheet

Prime Bidder Information

Company: Scott Construction, Inc.
Address: P.O. Box 340 Lake Delton, WI 53940
Telephone Number: 608-254-2555 Fax Number: 608-254-2249
Contact Person/Title: Caroline Haswell, Contract Administrator

Prime Bidder Certification

I, John A. Scott, Vice President of
Name Title
Scott Construction, Inc. certify that the information
Company

contained in this SBE Compliance Report is true and correct to the best of my knowledge and belief.

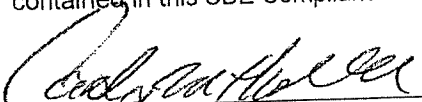
Witness' Signature

03/19/2020
Date

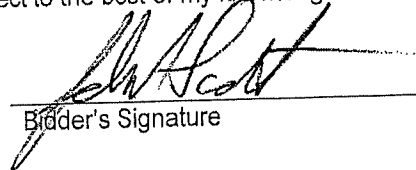
Bidder's Signature

CHIP SEALING 2020 - EAST

CONTRACT NO. 8509

DATE: 3/19/20

Scott Construction Inc.

Item	Quantity	Price	Extension
Section B: Proposal Page			
1 - AMNICON TRL:COTTAGE GROVE RD-WYALUSING DR - LUMP SUM	1.00	\$9,530.26	\$9,530.26
2 - ANNESTOWN DR:BROAD CREEK BLVD (S)-WYALUSING DR - LUMP SUM	1.00	\$6,447.53	\$6,447.53
3 - APOLLO WAY:ORION TRL-GALILEO DR - LUMP SUM	1.00	\$9,231.36	\$9,231.36
4 - ARGOSY CT:ATLAS AVE-NEPTUNE CT - LUMP SUM	1.00	\$8,408.39	\$8,408.39
5 - AZTALAN DR:WYALUSING DR-AMNICON TRL - LUMP SUM	1.00	\$11,919.83	\$11,919.83
6 - BAILEY DR:STOCKBRIDGE DR-BLUFF POINT DR - LUMP SUM	1.00	\$3,230.98	\$3,230.98
7 - BELMONT RD:MILWAUKEE ST CUL-DE-SAC-PORTLAND PKWY - LUMP SUM	1.00	\$4,756.71	\$4,756.71
8 - BLUFF POINT DR:WYALUSING DR-STOCKBRIDGE DR - LUMP SUM	1.00	\$11,403.77	\$11,403.77
9 - BROAD CREEK BLVD (N):S SPRECHER RD-WYALUSING DR - LUMP SUM	1.00	\$4,443.39	\$4,443.39
10 - BROAD CREEK BLVD (S):S SPRECHER RD-WYALUSING DR - LUMP SUM	1.00	\$4,443.39	\$4,443.39
11 - BROMLEY CIR:MEADOWLARK DR-189 FT E OF MEADOWLARK DR - LUMP SUM	1.00	\$1,041.73	\$1,041.73
12 - BROOKSHIRE LN:MERRYTURN RD-ST ALBANS AVE - LUMP SUM	1.00	\$4,891.34	\$4,891.34
13 - BUCKHORN DR:WYALUSING DR-AZTALAN DR - LUMP SUM	1.00	\$3,909.71	\$3,909.71
14 - CALLISTO DR:CALLISTO DR (NB)-KILPATRICK LN - LUMP SUM	1.00	\$4,066.77	\$4,066.77
15 - CAPRICORN LN:GALILEO DR-TRAVELER LN - LUMP SUM	1.00	\$1,923.20	\$1,923.20
16 - CAPRICORN LN - VICKSBURG RD ALLEY:CAPRICORN LN-VICKSBURG RD - LUMP SUM	1.00	\$472.79	\$472.79
17 - CARINA LN:GALILEO DR-SHARPSBURG DR - LUMP SUM	1.00	\$983.24	\$983.24
18 - CARLTON DR:MURLEY DR-SUMMERTOWN DR - LUMP SUM	1.00	\$4,773.54	\$4,773.54
19 - CAVENDISH CT:MERRYTURN RD-N END - LUMP SUM	1.00	\$1,295.76	\$1,295.76
20 - COACH HOUSE DR:STAGE HOUSE TRL-RETANA DR - LUMP SUM	1.00	\$11,950.48	\$11,950.48
21 - COBBLESTONE CT:RETANA DR-NORTH END - LUMP SUM	1.00	\$1,220.03	\$1,220.03
22 - COPERNICUS WAY:NORTH STAR DR-SHARPSBURG DR - LUMP SUM	1.00	\$5,727.13	\$5,727.13
23 - COPERNICUS WAY - GALILEO DR ALLEY:COPERNICUS WAY-GALILEO DR - LUMP SUM	1.00	\$1,093.82	\$1,093.82
24 - COPERNICUS WAY - GALILEO DR ALLEY:COPERNICUS WAY-GALILEO DR - LUMP SUM	1.00	\$1,129.88	\$1,129.88
25 - CORINTH TRL:SEVEN PINES AVE-VICKSBURG RD - LUMP SUM	1.00	\$3,315.12	\$3,315.12
26 - DAFFODIL LN:HAMLET PL-PICCADILLY DR - LUMP SUM	1.00	\$1,133.09	\$1,133.09
27 - DIAMOND DR:PORTLAND PKWY-CRYSTAL LN - LUMP SUM	1.00	\$10,064.75	\$10,064.75
28 - DOMINION DR:S SPRECHER RD-HIGHCLIFF TRL - LUMP SUM	1.00	\$15,308.67	\$15,308.67
29 - DORFMEISTER CT:MEADOWLARK DR-W END - LUMP SUM	1.00	\$1,880.33	\$1,880.33
30 - DRISCOLL DR:388 FT W OF RUSTIC DR-177 FT E OF KATHERINE CT - LUMP SUM	1.00	\$4,178.95	\$4,178.95
31 - EAST HILL PKWY:EAST HILL PKWY MEDIAN-EAST HILL PKWY MEDIAN - LUMP SUM	1.00	\$6,800.92	\$6,800.92
32 - EAST HILL PKWY (E):RESTON HEIGHTS DR-BLUFF POINT DR - LUMP SUM	1.00	\$8,204.25	\$8,204.25

CHIP SEALING 2020 - EAST

CONTRACT NO. 8509

DATE: 3/19/20

Scott Construction Inc.

Item	Quantity	Price	Extension
33 - EAST HILL PKWY (W):RESTON HEIGHTS DR-BLUFF POINT DR - LUMP SUM	1.00	\$8,204.25	\$8,204.25
34 - ELDON CT:COTTAGE GROVE RD-250 FT N OF COTTAGE GROVE RD - LUMP SUM	1.00	\$1,525.74	\$1,525.74
35 - ELLIE CIR:VERNON AVE-168 FT NW OF VERNON AVE - LUMP SUM	1.00	\$1,189.18	\$1,189.18
36 - FLORA LN:MARTHA LN-COTTAGE GROVE LN - LUMP SUM	1.00	\$3,623.63	\$3,623.63
37 - GALILEO DR - COPERNICUS WAY ALLEY:GALILEO DR-COPERNICUS WAY - LUMP SUM	1.00	\$1,509.71	\$1,509.71
38 - GALILEO DR:CAPRICORN LN-SHARPSBURG DR - LUMP SUM	1.00	\$6,344.16	\$6,344.16
39 - GEM CT:TRAFALGER PL-S END - LUMP SUM	1.00	\$1,419.16	\$1,419.16
40 - GEMINI DR:JUPITER DR-SHARPSBURG DR - LUMP SUM	1.00	\$7,372.27	\$7,372.27
41 - GOLDEN MAPLE RD ALLEY:GOLDEN MAPLE RD-SHADY LEAF RD - LUMP SUM	1.00	\$432.72	\$432.72
42 - GOLDEN MAPLE RD ALLEY:GOLDEN MAPLE RD ALLEY-GOLDEN MAPLE RD ALLEY - LUMP SUM	1.00	\$891.88	\$891.88
43 - GOLDEN MAPLE RD ALLEY:GOLDEN MAPLE RD-SHADY LEAF RD - LUMP SUM	1.00	\$432.72	\$432.72
44 - GOLDFINCH DR:TOPAZ LN-ACEWOOD BLVD - LUMP SUM	1.00	\$2,305.44	\$2,305.44
45 - GREENBRIAR LN:MERRYTURN RD-HARMONY HILL DR - LUMP SUM	1.00	\$6,955.57	\$6,955.57
46 - HACKNEY WAY:LAMPLIGHTER WAY-COACH HOUSE DR - LUMP SUM	1.00	\$6,983.62	\$6,983.62
47 - HALLEY WAY:JUPITER DR-HERCULES TRL - LUMP SUM	1.00	\$4,359.25	\$4,359.25
48 - HARRINGTON CT:AMNICON TRL-192 FT W OF AMNICON TRL - LUMP SUM	1.00	\$1,503.30	\$1,503.30
49 - HARRINGTON DR:AMNICON TRL-COTTAGE GROVE RD - LUMP SUM	1.00	\$11,096.86	\$11,096.86
50 - HAVENSWOOD DR:POTAWATOMI DR-HARRINGTON DR - LUMP SUM	1.00	\$3,525.87	\$3,525.87
51 - HERCULES TRL - ORION TRL ALLEY:HERCULES TRL - ORION TRL ALLEY-HERCULES TRL - ORION TRL ALLEY - LUMP SUM	1.00	\$449.55	\$449.55
52 - HERCULES TRL - ORION TRL ALLEY:HERCULES TRL-ORION TRL - LUMP SUM	1.00	\$480.80	\$480.80
53 - HERCULES TRL - ORION TRL ALLEY:HERCULES TRL - ORION TRL ALLEY-ORION TRL - LUMP SUM	1.00	\$480.80	\$480.80
54 - HERNDON DR:WYALUSING DR-1042 FT S OF WYALUSING DR - LUMP SUM	1.00	\$6,282.45	\$6,282.45
55 - HIGHCLIFF CT:AMNICON TRL-203 FT W OF AMNICON TRL - LUMP SUM	1.00	\$1,705.24	\$1,705.24
56 - HIGHCLIFF TRL:BLUFF POINT DR-AMNICON TRL - LUMP SUM	1.00	\$12,099.33	\$12,099.33
57 - HITCHING POST CT:RETANA DR-S END - LUMP SUM	1.00	\$1,430.38	\$1,430.38
58 - HOPEWELL DR:S SPRECHER RD-ANNETOWN DR - LUMP SUM	1.00	\$4,807.20	\$4,807.20
59 - HUMMINGBIRD LN:AGATE LN-RETANA DR - LUMP SUM	1.00	\$3,702.16	\$3,702.16
60 - INWOOD WAY:OPENWOOD WAY-COTTAGE GROVE RD - LUMP SUM	1.00	\$3,158.05	\$3,158.05
61 - JADE LN:HUMMINGBIRD LN-MEADOWLARK DR - LUMP SUM	1.00	\$3,825.57	\$3,825.57
62 - JOSHUA CIR:S THOMPSON DR-N END - LUMP SUM	1.00	\$4,997.92	\$4,997.92
63 - JUBILEE CIR:JUBILEE LN-155 FT W OF JUBILEE LN - LUMP SUM	1.00	\$1,632.32	\$1,632.32

CHIP SEALING 2020 - EAST

CONTRACT NO. 8509

DATE: 3/19/20

Scott Construction Inc.

Item	Quantity	Price	Extension
64 - JUBILEE LN:RUSTIC DR-DOMINION DR - LUMP SUM	1.00	\$3,735.82	\$3,735.82
65 - KEVINS WAY:VALLEY RD-HARMONY HILL DR - LUMP SUM	1.00	\$9,339.54	\$9,339.54
66 - KILPATRICK LN:243 FT W OF MCLEAN DR-445 FT E OF McCLELLAN DR - LUMP SUM	1.00	\$7,011.67	\$7,011.67
67 - KILPATRICK LN:351 FT W OF S SPRECHER RD-S SPRECHER RD - LUMP SUM	1.00	\$2,179.63	\$2,179.63
68 - KINGSBRIDGE RD:MERRYTURN RD-QUEENSBRIDGE RD - LUMP SUM	1.00	\$8,946.89	\$8,946.89
69 - LAMPLIGHTER WAY:MILWAUKEE ST-HACKNEY WAY - LUMP SUM	1.00	\$3,561.33	\$3,561.33
70 - MALVERN HILL DR:DOMINION DR-SHARPSBURG DR - LUMP SUM	1.00	\$8,571.06	\$8,571.06
71 - MARTHA LN:VERNON AVE-ACEWOOD BLVD - LUMP SUM	1.00	\$3,337.55	\$3,337.55
72 - MCCLELLAN DR:TRAVELER LN-COTTAGE GROVE RD - LUMP SUM	1.00	\$8,910.83	\$8,910.83
73 - MCLEAN DR:NORTH STAR DR-COTTAGE GROVE RD - LUMP SUM	1.00	\$21,680.47	\$21,680.47
74 - MEADOWLARK DR:MILWAUKEE ST-COTTAGE GROVE RD - LUMP SUM	1.00	\$42,518.75	\$42,518.75
75 - MERRYTURN RD:VICAR LN-QUEENSBRIDGE RD - LUMP SUM	1.00	\$10,753.09	\$10,753.09
76 - METRO TER:MILWAUKEE ST-TOWN CENTER DR - LUMP SUM	1.00	\$4,795.98	\$4,795.98
77 - MILKY WAY:APOLLO WAY-GALILEO DR - LUMP SUM	1.00	\$6,562.92	\$6,562.92
78 - MILKY WAY - MILKY WAY ALLEY:MILKY WAY-MILKY WAY - LUMP SUM	1.00	\$1,387.11	\$1,387.11
79 - MILKY WAY - ORION TRL ALLEY:ORION TRL - MILKY WAY ALLEY-ORION TRL - LUMP SUM	1.00	\$367.81	\$367.81
80 - MILKY WAY ALLEY:MILKY WAY-MILKY WAY - LUMP SUM	1.00	\$1,117.86	\$1,117.86
81 - MILL BLUFF DR:WYALUSING DR-AZTALAN DR - LUMP SUM	1.00	\$3,926.53	\$3,926.53
82 - MILWAUKEE ST:1188 FT E OF NORTH STAR DR-WIND STONE DR - LUMP SUM	1.00	\$47,176.10	\$47,176.10
83 - MURLEY DR:RESTON HEIGHTS DR-BROAD CREEK BLVD (S) - LUMP SUM	1.00	\$5,827.30	\$5,827.30
84 - N SPRECHER RD:MILWAUKEE ST-COMMERCIAL AVE - LUMP SUM	1.00	\$25,542.50	\$25,542.50
85 - NEPTUNE CT:ATLAS AVE-ROBERTSON RD - LUMP SUM	1.00	\$5,474.71	\$5,474.71
86 - NORTH STAR DR:MCLEAN DR-COTTAGE GROVE RD - LUMP SUM	1.00	\$21,648.82	\$21,648.82
87 - NOTTING HILL WAY:WYALUSING DR-574 FT S OF WYALUSING DR - LUMP SUM	1.00	\$3,107.57	\$3,107.57
88 - OPAL CT:TRAFALGER PL-S END - LUMP SUM	1.00	\$1,379.90	\$1,379.90
89 - OPEN WOOD WAY:KINGSBRIDGE RD-QUEENSBRIDGE RD - LUMP SUM	1.00	\$1,654.75	\$1,654.75
90 - ORION TRL:CARTER MOON PASS-SHARPSBURG DR - LUMP SUM	1.00	\$11,499.13	\$11,499.13
91 - ORION TRL - MILKY WAY ALLEY:ORION TRL-ORION TRL - MILKY WAY ALLEY - LUMP SUM	1.00	\$474.79	\$474.79
92 - ORION TRL - MILKY WAY ALLEY:ORION TRL - MILKY WAY ALLEY-ORION TRL - MILKY WAY ALLEY - LUMP SUM	1.00	\$1,644.34	\$1,644.34

CHIP SEALING 2020 - EAST

CONTRACT NO. 8509

DATE: 3/19/20

Scott Construction Inc.

Item	Quantity	Price	Extension
93 - ORION TRL - MILKY WAY ALLEY:ORION TRL-MILKY WAY - LUMP SUM	1.00	\$394.26	\$394.26
94 - ORION TRL - MILKY WAY ALLEY:ORION TRL-MILKY WAY - LUMP SUM	1.00	\$423.10	\$423.10
95 - ORION TRL - MILKY WAY ALLEY:ORION TRL - MILKY WAY ALLEY-ORION TRL - MILKY WAY ALLEY - LUMP SUM	1.00	\$1,250.08	\$1,250.08
96 - ORION TRL - MILKY WAY ALLEY:ORION TRL-MILKY WAY - LUMP SUM	1.00	\$466.38	\$466.38
97 - PICCADILLY DR:DAFFODIL LN-KURT DR - LUMP SUM	1.00	\$7,684.79	\$7,684.79
98 - PORTIA CT:VICKSBURG RD-138 FT N OF VICKSBURG DR - LUMP SUM	1.00	\$1,139.50	\$1,139.50
99 - PORTSMOUTH WAY:MERRYTURN RD-161 FT TO EAST END - LUMP SUM	1.00	\$5,901.02	\$5,901.02
100 - POTAWATOMI DR:HAVENSWOOD DR-HARRINGTON DR - LUMP SUM	1.00	\$4,660.55	\$4,660.55
101 - QUEENSBRIDGE RD:KINGSBRIDGE RD-WHITEHALL DR - LUMP SUM	1.00	\$3,926.53	\$3,926.53
102 - RADFORD DR:MURLEY DR-SUMMERTOWN DR - LUMP SUM	1.00	\$3,180.49	\$3,180.49
103 - RESTON HEIGHTS DR:MURLEY DR-EAST HILL PKWY - LUMP SUM	1.00	\$11,513.56	\$11,513.56
104 - RETANA DR:MEADOWLARK DR-MERRYTURN RD - LUMP SUM	1.00	\$10,197.77	\$10,197.77
105 - ROBERTSON RD:ATLAS AVE-NEPTUNE CT - LUMP SUM	1.00	\$10,500.67	\$10,500.67
106 - RODEFELD WAY:WYALUSING DR-399 FT S OF WYALUSING DR - LUMP SUM	1.00	\$2,153.98	\$2,153.98
107 - RUSTIC DR:MILWAUKEE ST-S SPRECHER RD - LUMP SUM	1.00	\$19,173.90	\$19,173.90
108 - S SPRECHER RD:MILWAUKEE ST-COTTAGE GROVE RD - LUMP SUM	1.00	\$57,982.88	\$57,982.88
109 - S THOMPSON DR:MILWAUKEE ST-221 FT SOUTH TO END - LUMP SUM	1.00	\$7,709.63	\$7,709.63
110 - S WALBRIDGE AVE:MILWAUKEE ST-PORTLAND PKWY - LUMP SUM	1.00	\$12,738.80	\$12,738.80
111 - SEVEN PINES AVE:SEVEN PINES CT-MALVERN HILL DR - LUMP SUM	1.00	\$5,733.54	\$5,733.54
112 - SEVEN PINES CT:SEVEN PINES AVE-140 FT S OF SEVEN PINES AVE - LUMP SUM	1.00	\$1,189.98	\$1,189.98
113 - SHARPSBURG DR:NORTH STAR DR-S SPRECHER RD - LUMP SUM	1.00	\$25,754.05	\$25,754.05
114 - ST ALBANS AVE:462 FT N OF SEVERN WAY-PORTSMOUTH WAY - LUMP SUM	1.00	\$10,854.06	\$10,854.06
115 - STAGE HOUSE TRL:LAMPLIGHTER WAY-COACH HOUSE DR - LUMP SUM	1.00	\$5,600.52	\$5,600.52
116 - STOCKBRIDGE DR:WYALUSING DR-BLUFF POINT DR - LUMP SUM	1.00	\$6,658.28	\$6,658.28
117 - SUDBURY WAY:HACKNEY WAY-COACH HOUSE DR - LUMP SUM	1.00	\$6,274.44	\$6,274.44
118 - SUDBURY WAY:MERRYTURN RD-ST ALBANS AVE - LUMP SUM	1.00	\$3,993.85	\$3,993.85
119 - SUMMERTOWN DR:MILWAUKEE ST-WYALUSING DR - LUMP SUM	1.00	\$7,897.94	\$7,897.94

CHIP SEALING 2020 - EAST

CONTRACT NO. 8509

DATE: 3/19/20

Scott Construction Inc.

Item	Quantity	Price	Extension
120 - TASMAN ST:NEPTUNE CT-ARGOSY CT - LUMP SUM	1.00	\$3,881.66	\$3,881.66
121 - TOPAZ LN:ONYX LN-MARTHA LN - LUMP SUM	1.00	\$12,183.47	\$12,183.47
122 - TOWN CENTER DR:657 FT W OF METRO TER-N SPRECHER RD - LUMP SUM	1.00	\$10,024.68	\$10,024.68
123 - TRAFALGER PL:DAFFODIL LN-KURT DR - LUMP SUM	1.00	\$6,338.55	\$6,338.55
124 - TRAVELER LN:DOMINION DR-MC CLELLAN DR - LUMP SUM	1.00	\$7,067.76	\$7,067.76
125 - TRAVELER LN:CALLISTO DR (SB)-CAPRICORN LN - LUMP SUM	1.00	\$1,329.41	\$1,329.41
126 - TWIN OAKS DR:217 FT W OF MEADOWLARK DR-VALLEY RD - LUMP SUM	1.00	\$4,746.50	\$4,746.50
127 - VALLEY RD:KEVINS WAY-TWIN OAKS DR - LUMP SUM	1.00	\$3,085.13	\$3,085.13
128 - VERNON AVE:TOPAZ LN-COTTAGE GROVE RD - LUMP SUM	1.00	\$17,161.35	\$17,161.35
129 - VICAR LN:MERRYTURN RD-WHITEHALL DR - LUMP SUM	1.00	\$5,749.57	\$5,749.57
130 - VICKSBURG CT:MALVERN HILL DR-206 FT SE OF MALVERN HILL DR - LUMP SUM	1.00	\$1,234.05	\$1,234.05
131 - VICKSBURG RD:GALILEO DR-MALVERN HILL DR - LUMP SUM	1.00	\$7,140.68	\$7,140.68
132 - WESTMINSTER CT:N END-PORTSMOUTH WAY - LUMP SUM	1.00	\$2,692.48	\$2,692.48
133 - WHITEFISH CT:AMNICON TRL-202 FT W OF AMNICON TRL - LUMP SUM	1.00	\$1,475.25	\$1,475.25
134 - WINDSOR CT:N END-PORTSMOUTH WAY - LUMP SUM	1.00	\$2,877.59	\$2,877.59
135 - WYALUSING DR:MILWAUKEE ST-S SPRECHER RD - LUMP SUM	1.00	\$42,723.89	\$42,723.89
136 - ALBERT CT:MAYFAIR AVE-E END - LUMP SUM	1.00	\$1,692.82	\$1,692.82
137 - ANCHOR DR:DEMPSEY RD-BERGEN ST - LUMP SUM	1.00	\$3,388.04	\$3,388.04
138 - BERGEN ST:ANCHOR DR-STEINIES DR - LUMP SUM	1.00	\$3,174.88	\$3,174.88
139 - BEWICK DR:COMMERCIAL AVE SERVICE DR-NAKOOSA TRL - LUMP SUM	1.00	\$6,882.65	\$6,882.65
140 - BRIGHAM AVE:MAYFAIR AVE-ROSEDALE AVE - LUMP SUM	1.00	\$4,844.06	\$4,844.06
141 - BUCKINGHAM LN:149 FT N OF DAWES ST-TULANE AVE - LUMP SUM	1.00	\$8,432.83	\$8,432.83
142 - BUSSE ST:MARGARET ST-605 FT S OF OLBRICH AVE - LUMP SUM	1.00	\$6,917.11	\$6,917.11
143 - CALVERT RD:SILVER RD-DEMPSEY RD - LUMP SUM	1.00	\$2,505.37	\$2,505.37
144 - CHERRY AVE:BRIGHAM AVE-CONCORD AVE - LUMP SUM	1.00	\$3,411.68	\$3,411.68
145 - CLOVER LN:SARGENT ST-478 FT S OF OLBRICH AVE - LUMP SUM	1.00	\$6,135.81	\$6,135.81
146 - COMMERCIAL AVE SERVICE RD:N FAIR OAKS AVE-JACOBSON AVE - LUMP SUM	1.00	\$3,892.88	\$3,892.88
147 - COMMERCIAL AVE SERVICE RD:W END-LEXINGTON AVE - LUMP SUM	1.00	\$11,779.60	\$11,779.60
148 - COMMERCIAL AVE SERVICE RD:NAKOOSA TRL-PULLEY DR - LUMP SUM	1.00	\$20,911.59	\$20,911.59
149 - CONCORD AVE:W END-CHERRY AVE - LUMP SUM	1.00	\$4,271.11	\$4,271.11
150 - CONLIN ST:ZIEGLER RD-PULLEY DR - LUMP SUM	1.00	\$5,384.96	\$5,384.96
151 - CORAL CT:ROCKWELL DR-224 FT S OF ROCKWELL DR - LUMP SUM	1.00	\$1,630.31	\$1,630.31
152 - DELLA CT:MC CANN RD-N END - LUMP SUM	1.00	\$1,536.56	\$1,536.56
153 - DENNETT DR:ATWOOD AVE-DEMPSEY RD - LUMP SUM	1.00	\$20,873.13	\$20,873.13
154 - ESTHER CT:MC CANN RD-N END - LUMP SUM	1.00	\$1,635.52	\$1,635.52
155 - FAIRMONT AVE:HOME AVE-CONCORD AVE - LUMP SUM	1.00	\$6,557.71	\$6,557.71

CHIP SEALING 2020 - EAST

CONTRACT NO. 8509

DATE: 3/19/20

Scott Construction Inc.

Item	Quantity	Price	Extension
156 - FARRELL ST:JUDD ST-RICHARD ST - LUMP SUM	1.00	\$2,104.30	\$2,104.30
157 - GUNDERSON ST:DENNETT DR-MARGARET ST - LUMP SUM	1.00	\$1,390.71	\$1,390.71
158 - HARDING ST:MILWAUKEE ST-HARGROVE ST - LUMP SUM	1.00	\$11,740.33	\$11,740.33
159 - HYNEK RD:SILVER RD-DEMPSEY RD - LUMP SUM	1.00	\$2,411.61	\$2,411.61
160 - JANA LN:N THOMPSON DR-SYCAMORE AVE - LUMP SUM	1.00	\$12,233.96	\$12,233.96
161 - KIM LN:JANA LN-ROCKEFELLER LN - LUMP SUM	1.00	\$1,963.27	\$1,963.27
162 - LEVINE CT:STEIN AVE-S END - LUMP SUM	1.00	\$1,369.88	\$1,369.88
163 - LORI CIR:DEMPSEY RD-616 FT E OF DEMPSEY RD - LUMP SUM	1.00	\$3,613.21	\$3,613.21
164 - LYNNHAVEN RD:CALVERT RD-HYNEK RD - LUMP SUM	1.00	\$3,635.65	\$3,635.65
165 - MARGARET ST:GUNDERSON ST-DEMPSEY RD - LUMP SUM	1.00	\$5,812.87	\$5,812.87
166 - MAYFAIR AVE:LEXINGTON AVE-ALBERT CT - LUMP SUM	1.00	\$7,637.51	\$7,637.51
167 - MCCANN RD:LEVINE CT-STEIN AVE - LUMP SUM	1.00	\$6,122.99	\$6,122.99
168 - N FAIR OAKS AVE:COMMERCIAL AVE SERVICE RD, N-E WASHINGTON AVE - LUMP SUM	1.00	\$15,946.53	\$15,946.53
169 - N STOUGHTON RD SERVICE RD:LEXINGTON AVE-PRAIRIE AVE - LUMP SUM	1.00	\$12,080.10	\$12,080.10
170 - N WALBRIDGE AVE:MILWAUKEE ST-78 FT NE OF WITWERT RD - LUMP SUM	1.00	\$12,707.54	\$12,707.54
171 - NAKOOSA TRL:360 FT W OF COMMERCIAL AVE-ZIEGLER RD - LUMP SUM	1.00	\$10,124.85	\$10,124.85
172 - OLBRICH AVE:ATWOOD AVE-SILAS ST - LUMP SUM	1.00	\$8,156.77	\$8,156.77
173 - ONTARIO ST:TULANE AVE-ROCKWELL DR - LUMP SUM	1.00	\$6,187.90	\$6,187.90
174 - PAUS ST:SCHENK ST-DEMPSEY RD - LUMP SUM	1.00	\$8,625.55	\$8,625.55
175 - POWERS AVE:BURKE AVE-LEXINGTON AVE - LUMP SUM	1.00	\$5,780.62	\$5,780.62
176 - PRAIRIE AVE:MAYFAIR AVE-N STOUGHTON RD SERVICE RD - LUMP SUM	1.00	\$5,693.47	\$5,693.47
177 - PRENTICE PL:N THOMPSON DR-509 FT N OF N THOMPSON DR - LUMP SUM	1.00	\$2,832.71	\$2,832.71
178 - PULLEY DR:COMMERCIAL AVE-NAKOOSA TRL - LUMP SUM	1.00	\$7,039.71	\$7,039.71
179 - REDLAND DR:COMMERCIAL AVE SERVICE RD-NAKOOSA TRL - LUMP SUM	1.00	\$6,854.61	\$6,854.61
180 - RICHARD ST:FARRELL ST-HARDING ST - LUMP SUM	1.00	\$3,140.83	\$3,140.83
181 - ROCKEFELLER LN:KIM LN-JANA LN - LUMP SUM	1.00	\$4,049.94	\$4,049.94
182 - ROCKWELL DR:ONTARIO ST-BERGEN ST - LUMP SUM	1.00	\$6,005.59	\$6,005.59
183 - ROSEDALE AVE:BRIGHAM AVE-CONCORD AVE - LUMP SUM	1.00	\$4,333.61	\$4,333.61
184 - S STOUGHTON RD SERVICE RD (W):ALLIS AVE-PFLAUM RD - LUMP SUM	1.00	\$17,792.81	\$17,792.81
185 - SINYKIN CIR:STEIN AVE-W END - LUMP SUM	1.00	\$4,594.04	\$4,594.04
186 - STEIN AVE:LEVINE CT-SWANTON RD - LUMP SUM	1.00	\$7,448.19	\$7,448.19
187 - STEINIES DR:DEMPSEY RD-BERGEN ST - LUMP SUM	1.00	\$3,298.29	\$3,298.29
188 - SUSSEX LN:SCHENK ST-BUCKINGHAM LN - LUMP SUM	1.00	\$5,297.21	\$5,297.21
189 - SWANTON RD:MILWAUKEE ST-N THOMPSON DR - LUMP SUM	1.00	\$15,644.03	\$15,644.03
190 - WALSH RD:COMMERCIAL AVE SERVICE RD-NAKOOSA TRL - LUMP SUM	1.00	\$8,834.70	\$8,834.70
191 - WILSHIRE LN:SCHENK ST-BUCKINGHAM LN - LUMP SUM	1.00	\$4,781.56	\$4,781.56
192 - WITWERT RD:MILWAUKEE ST-N WALBRIDGE AVE - LUMP SUM	1.00	\$11,171.39	\$11,171.39

CHIP SEALING 2020 - EAST

CONTRACT NO. 8509

DATE: 3/19/20

Scott Construction Inc.

Item	Quantity	Price	Extension
193 - ZIEGLER RD:COMMERCIAL AVE SERVICE RD-NAKOOSA TRL - LUMP SUM	1.00	\$7,052.94	\$7,052.94
21041 - INLET PROTECTION, TYPE D - COMPLETE - EACH	10.00	\$5,390.00	\$53,900.00
60800 - PAVEMENT MARKING EPOXY, 4-INCH SOLID WHITE (edge line) - L.F.	2250.00	\$0.50	\$1,125.00
60800 - PAVEMENT MARKING EPOXY, 4-INCH SOLID YELLOW - L.F.	2850.00	\$0.50	\$1,425.00
60801 - PAVEMENT MARKING EPOXY, 4-INCH DOUBLE YELLOW - L.F.	3500.00	\$0.90	\$3,150.00
60802 - PAVEMENT MARKING EPOXY, 6-INCH SOLID WHITE - L.F.	40500.00	\$0.70	\$28,350.00
60802 - PAVEMENT MARKING EPOXY, 6-INCH WHITE SKIPS, (2' Line, 6' GAP) - L.F.	200.00	\$0.70	\$140.00
60802 - PAVEMENT MARKING EPOXY, 6-INCH WHITE SKIPS, (10' LINE 30' GAP) - L.F.	3100.00	\$0.70	\$2,170.00
60802 - PAVEMENT MARKING EPOXY, 6-INCH YELLOW SKIPS, (10' LINE 30' GAP) - L.F.	1700.00	\$0.70	\$1,190.00
60803 - PAVEMENT MARKING EPOXY, 8-INCH SOLID WHITE - L.F.	2800.00	\$0.90	\$2,520.00
60803 - PAVEMENT MARKING EPOXY, 8-INCH WHITE SKIPS, (2' Line, 6' GAP) - L.F.	250.00	\$0.90	\$225.00
60803 - PAVEMENT MARKING EPOXY, 8-INCH WHITE SKIPS, (5' Line, 5' GAP) - L.F.	490.00	\$0.90	\$441.00
60812 - PAVEMENT MARKING EPOXY, CROSSWALK, 6-INCH - L.F.	5125.00	\$6.25	\$32,031.25
60814 - PAVEMENT MARKING EPOXY, CROSSWALK, 12-INCH - L.F.	110.00	\$7.50	\$825.00
60815 - PAVEMENT MARKING EPOXY, CROSSWALK, 18-INCH - L.F.	135.00	\$9.25	\$1,248.75
60818 - PAVEMENT MARKING EPOXY, STOP LINE, 24-INCH - L.F.	850.00	\$10.50	\$8,925.00
60823 - PAVEMENT MARKING EPOXY, SYMBOL, BIKE SYMBOL - Each	9.00	\$185.00	\$1,665.00
60829 - PAVEMENT MARKING EPOXY, SYMBOL, LEFT ARROW - Each	4.00	\$225.00	\$900.00
60834 - PAVEMENT MARKING EPOXY, WORD, ONLY - Each	2.00	\$350.00	\$700.00
60810 - PAVEMENT MARKING EPOXY, DIAGONAL LINE, 8-INCH - L.F.	225.00	\$7.00	\$1,575.00
60881 - PAVEMENT MARKING REMOVAL, 6-INCH WHITE SKIPS, (2' LINE 6' GAP) - L.F.	200.00	\$1.50	\$300.00
60881 - PAVEMENT MARKING REMOVAL, 6-INCH WHITE SKIPS, (10' LINE 30' GAP) - L.F.	5500.00	\$1.50	\$8,250.00
60881 - PAVEMENT MARKING REMOVAL, 6-INCH YELLOW RADIUS SKIPS, (5' LINE 5' GAP) - L.F.	400.00	\$1.50	\$600.00
60881 - PAVEMENT MARKING REMOVAL, 6-INCH YELLOW SKIPS, (10' LINE 30' GAP) - L.F.	6500.00	\$1.50	\$9,750.00
60882 - PAVEMENT MARKING REMOVAL, 8-INCH WHITE SKIPS, (2' LINE 6' GAP) - L.F.	50.00	\$1.50	\$75.00
60882 - PAVEMENT MARKING REMOVAL, 8-INCH WHITE SKIPS, (5' LINE 5' GAP) - L.F.	2000.00	\$1.50	\$3,000.00
194 - BURKE AVE:W END-MAYFAIR AVE - LUMP SUM	1.00	\$9,083.11	\$9,083.11
195 - CARPENTER ST:E WASHINGTON AVE-QUINCY AVE - LUMP SUM	1.00	\$2,404.00	\$2,404.00
196 - CHRISTIANSON AVE:COMMERCIAL AVE SERVICE RD-LEXINGTON AVE - LUMP SUM	1.00	\$6,385.63	\$6,385.63

CHIP SEALING 2020 - EAST

CONTRACT NO. 8509

DATE: 3/19/20

Scott Construction Inc.

Item	Quantity	Price	Extension
197 - COMMERCIAL AVE SERVICE RD:JACOBSON AVE-MAYFAIR AVE - LUMP SUM	1.00	\$3,533.88	\$3,533.88
198 - E WASHINGTON AVE FRONTAGE RD:E WASHINGTON AVE-N STOUGHTON RD FRONTAGE RD - LUMP SUM	1.00	\$2,961.73	\$2,961.73
199 - FAIRMONT AVE:COMMERCIAL AVE SERVICE RD-HOME AVE - LUMP SUM	1.00	\$3,485.80	\$3,485.80
200 - GRACELAND AVE:REINDAHL AVE-ROWLAND AVE - LUMP SUM	1.00	\$4,732.88	\$4,732.88
201 - GROVER ST:E WASHINGTON AVE-107 FT NW TO EOP - LUMP SUM	1.00	\$1,752.92	\$1,752.92
202 - HOME AVE:W END-MAYFAIR AVE - LUMP SUM	1.00	\$5,704.69	\$5,704.69
203 - JACOBSON AVE:COMMERCIAL AVE SERVICE RD-LEXINGTON AVE - LUMP SUM	1.00	\$6,250.40	\$6,250.40
204 - N STOUGHTON RD FRONTAGE RD:PRAIRIE AVE-E WASHINGTON AVE FRONTAGE RD - LUMP SUM	1.00	\$2,961.73	\$2,961.73
205 - REINDAHL AVE:E WASHINGTON AVE-GRACELAND AVE - LUMP SUM	1.00	\$2,984.17	\$2,984.17
206 - RIDGEWAY AVE:MELVIN CT-237 FT NE OF GROVER ST - LUMP SUM	1.00	\$7,231.23	\$7,231.23
207 - RIDGEWAY AVE:REINDAHL AVE-ROWLAND AVE - LUMP SUM	1.00	\$5,684.46	\$5,684.46
208 - RIDGEWAY AVE:MENDOTA ST-711 FT NORTH TO END - LUMP SUM	1.00	\$2,797.66	\$2,797.66
209 - ROWLAND AVE:E WASHINGTON AVE-GRACELAND AVE - LUMP SUM	1.00	\$2,864.77	\$2,864.77
210 - SCHMEDEMAN AVE:E WASHINGTON AVE-GRACELAND AVE - LUMP SUM	1.00	\$2,916.85	\$2,916.85
235 Items	Totals		\$1,552,296.84



Department of Public Works
Engineering Division
Robert F. Phillips, P.E., City Engineer

City-County Building, Room 115
210 Martin Luther King, Jr. Boulevard
Madison, Wisconsin 53703
Phone: (608) 266-4751
Fax: (608) 264-9275
engineering@cityofmadison.com
www.cityofmadison.com/engineering

Deputy City Engineer
Gregory T. Fries, P.E.

Deputy Division Manager
Kathleen M. Cryan

Principal Engineer 2
Christopher J. Petykowski, P.E.
John S. Fahrney, P.E.

Principal Engineer 1
Christina M. Bachmann, P.E.
Mark D. Moder, P.E.
Janet Schmidt, P.E.
James M. Wolfe, P.E.

Facilities & Sustainability
Bryan Cooper, Principal Architect

Mapping Section Manager
Eric T. Pederson, P.S.

Financial Manager
Steven B. Danner-Rivers

BIENNIAL BID BOND

Scott Construction Inc.

(a corporation of the State of _____)
(individual), (partnership), (hereinafter referred to as the "Principal") and
Fidelity and Deposit Company of Maryland

a corporation of the State of Illinois _____ (hereinafter referred to as the "Surety") and licensed to do business in the State of Wisconsin, are held and firmly bound unto the City of Madison, Wisconsin (hereinafter referred to as the "City"), in the sum equal to the individual proposal guaranty amounts of the total bid or bids of the Principal herein accepted by the City, for the payment of which the Principal and the Surety hereby jointly and severally bind ourselves, our heirs, executors, administrators, successors and assigns.

The condition of this obligation is that the Principal has submitted to the City certain bids for projects from the time period of February 1, 2020 through January 31, 2022.

If the Principal is awarded the contract(s) by the City and, within the time and manner required by law after the prescribed forms are presented for its signature, the Principal enters into (a) written contract(s) in accordance with the bid(s), and files with the City its bond(s) guaranteeing faithful performance and payment for all labor and materials, as required by law, or if the City rejects all bids for the work described, then this obligation shall be null and void; otherwise, it shall remain in full force and effect.

In the event the Principal shall fail to execute and deliver the contract(s) or the performance and payment bond(s), all within the time specified or any extension thereof, the Principal and Surety agree jointly and severally to pay to the City within ten (10) calendar days of written demand a total equal to the sum of the individual proposal guaranty amounts of the total bid(s) as liquidated damages.

The Surety, for value received, hereby agrees that the obligations of it and its bond shall be in no way impaired or affected by any extension of time within which the City may accept a bid, and the Surety does hereby waive notice of any such extension.

This bond may be terminated by the Surety upon giving thirty (30) days written notice to the City of its intent to terminate this bond and to be released and discharged therefrom, but such termination shall not operate to relieve or discharge the Surety from any liability already accrued or which shall accrue before the expiration of such thirty (30) day period.

**ZURICH AMERICAN INSURANCE COMPANY
COLONIAL AMERICAN CASUALTY AND SURETY COMPANY
FIDELITY AND DEPOSIT COMPANY OF MARYLAND
POWER OF ATTORNEY**

KNOW ALL MEN BY THESE PRESENTS: That the ZURICH AMERICAN INSURANCE COMPANY, a corporation of the State of New York, the COLONIAL AMERICAN CASUALTY AND SURETY COMPANY, a corporation of the State of Illinois, and the FIDELITY AND DEPOSIT COMPANY OF MARYLAND a corporation of the State of Illinois (herein collectively called the "Companies"), by **Robert D. Murray, Vice President**, in pursuance of authority granted by Article V, Section 8, of the By-Laws of said Companies, which are set forth on the reverse side hereof and are hereby certified to be in full force and effect on the date hereof, do hereby nominate, constitute, and appoint, **Judith A. WALKER, David ZENOBI, Patrick A. MCKENNA, Brooke L. PARKER and Elizabeth MOSCA, all of Madison, Wisconsin, EACH**, its true and lawful agent and Attorney-in-Fact, to make, execute, seal and deliver, for, and on its behalf as surety, and as its act and deed: **any and all bonds and undertakings**, and the execution of such bonds or undertakings in pursuance of these presents, shall be as binding upon said Companies, as fully and amply, to all intents and purposes, as if they had been duly executed and acknowledged by the regularly elected officers of the ZURICH AMERICAN INSURANCE COMPANY at its office in New York, New York., the regularly elected officers of the COLONIAL AMERICAN CASUALTY AND SURETY COMPANY at its office in Owings Mills, Maryland., and the regularly elected officers of the FIDELITY AND DEPOSIT COMPANY OF MARYLAND at its office in Owings Mills, Maryland., in their own proper persons.

The said Vice President does hereby certify that the extract set forth on the reverse side hereof is a true copy of Article V, Section 8, of the By-Laws of said Companies, and is now in force.

IN WITNESS WHEREOF, the said Vice-President has hereunto subscribed his/her names and affixed the Corporate Seals of the said ZURICH AMERICAN INSURANCE COMPANY, COLONIAL AMERICAN CASUALTY AND SURETY COMPANY, and FIDELITY AND DEPOSIT COMPANY OF MARYLAND, this 4th day of March, A.D. 2019.



ATTEST:
ZURICH AMERICAN INSURANCE COMPANY
COLONIAL AMERICAN CASUALTY AND SURETY COMPANY
FIDELITY AND DEPOSIT COMPANY OF MARYLAND

By: *Robert D. Murray*
Vice President

By: *Dawn E. Brown*
Secretary

State of Maryland
County of Baltimore

On this 4th day of March, A.D. 2019, before the subscriber, a Notary Public of the State of Maryland, duly commissioned and qualified, **Robert D. Murray, Vice President and Dawn E. Brown, Secretary** of the Companies, to me personally known to be the individuals and officers described in and who executed the preceding instrument, and acknowledged the execution of same, and being by me duly sworn, depose and saith, that he/she is the said officer of the Company aforesaid, and that the seals affixed to the preceding instrument are the Corporate Seals of said Companies, and that the said Corporate Seals and the signature as such officer were duly affixed and subscribed to the said instrument by the authority and direction of the said Corporations.

IN TESTIMONY WHEREOF, I have hereunto set my hand and affixed my Official Seal the day and year first above written.



Constance A. Dunn

Constance A. Dunn, Notary Public
My Commission Expires: July 9, 2019

EXTRACT FROM BY-LAWS OF THE COMPANIES

"Article V, Section 8, Attorneys-in-Fact. The Chief Executive Officer, the President, or any Executive Vice President or Vice President may, by written instrument under the attested corporate seal, appoint attorneys-in-fact with authority to execute bonds, policies, recognizances, stipulations, undertakings, or other like instruments on behalf of the Company, and may authorize any officer or any such attorney-in-fact to affix the corporate seal thereto; and may with or without cause modify or revoke any such appointment or authority at any time."

CERTIFICATE

I, the undersigned, Vice President of the ZURICH AMERICAN INSURANCE COMPANY, the COLONIAL AMERICAN CASUALTY AND SURETY COMPANY, and the FIDELITY AND DEPOSIT COMPANY OF MARYLAND, do hereby certify that the foregoing Power of Attorney is still in full force and effect on the date of this certificate; and I do further certify that Article V, Section 8, of the By-Laws of the Companies is still in force.

This Power of Attorney and Certificate may be signed by facsimile under and by authority of the following resolution of the Board of Directors of the ZURICH AMERICAN INSURANCE COMPANY at a meeting duly called and held on the 15th day of December 1998.

RESOLVED: "That the signature of the President or a Vice President and the attesting signature of a Secretary or an Assistant Secretary and the Seal of the Company may be affixed by facsimile on any Power of Attorney...Any such Power or any certificate thereof bearing such facsimile signature and seal shall be valid and binding on the Company."

This Power of Attorney and Certificate may be signed by facsimile under and by authority of the following resolution of the Board of Directors of the COLONIAL AMERICAN CASUALTY AND SURETY COMPANY at a meeting duly called and held on the 5th day of May, 1994, and the following resolution of the Board of Directors of the FIDELITY AND DEPOSIT COMPANY OF MARYLAND at a meeting duly called and held on the 10th day of May, 1990.

RESOLVED: "That the facsimile or mechanically reproduced seal of the company and facsimile or mechanically reproduced signature of any Vice-President, Secretary, or Assistant Secretary of the Company, whether made heretofore or hereafter, wherever appearing upon a certified copy of any power of attorney issued by the Company, shall be valid and binding upon the Company with the same force and effect as though manually affixed.

IN TESTIMONY WHEREOF, I have hereunto subscribed my name and affixed the corporate seals of the said Companies,
this 6 day of January, 2020.



A handwritten signature in cursive script that reads "Michael C. Fay".

Michael C. Fay, Vice President

TO REPORT A CLAIM WITH REGARD TO A SURETY BOND, PLEASE SUBMIT A COMPLETE DESCRIPTION OF THE CLAIM INCLUDING THE PRINCIPAL ON THE BOND, THE BOND NUMBER, AND YOUR CONTACT INFORMATION TO:

Zurich Surety Claims
1299 Zurich Way
Schaumburg, IL 60196-1056
www.reportsfclaims@zurichna.com
800-626-4577

SECTION H: AGREEMENT

THIS AGREEMENT made this 1st day of April in the year Two Thousand and Twenty between **SCOTT CONSTRUCTION INC.** hereinafter called the Contractor, and the City of Madison, Wisconsin, hereinafter called the City.

WHEREAS, the Common Council of the said City of Madison under the provisions of a resolution adopted **MARCH 31, 2020**, and by virtue of authority vested in the said Council, has awarded to the Contractor the work of performing certain construction.

NOW, THEREFORE, the Contractor and the City, for the consideration hereinafter named, agree as follows:

1. **Scope of Work.** The Contractor shall, perform the construction, execution and completion of the following listed complete work or improvement in full compliance with the Plans, Specifications, Standard Specifications, Supplemental Specifications, Special Provisions and contract; perform all items of work covered or stipulated in the proposal; perform all altered or extra work; and shall furnish, unless otherwise provided in the contract, all materials, implements, machinery, equipment, tools, supplies, transportation, and labor necessary to the prosecution and completion of the work or improvements:

CHIP SEALING 2020 - EAST CONTRACT NO. 8509

2. **Completion Date/Contract Time.** Construction work must begin within seven (7) calendar days after the date appearing on mailed written notice to do so shall have been sent to the Contractor and shall be carried on at a rate so as to secure full completion SEE SPECIAL PROVISIONS, the rate of progress and the time of completion being essential conditions of this Agreement.
3. **Contract Price.** The City shall pay to the Contractor at the times, in the manner and on the conditions set forth in said specifications, the sum of **ONE MILLION FIVE HUNDRED FIFTY-TWO THOUSAND TWO HUNDRED NINETY-SIX AND 84/100 (\$1,552,296.84)** Dollars being the amount bid by such Contractor and which was awarded to him/her as provided by law.
4. **Affirmative Action.** In the performance of the services under this Agreement the Contractor agrees not to discriminate against any employee or applicant because of race, religion, marital status, age, color, sex, disability, national origin or ancestry, income level or source of income, arrest record or conviction record, less than honorable discharge, physical appearance, sexual orientation, gender identity, political beliefs, or student status. The Contractor further agrees not to discriminate against any subcontractor or person who offers to subcontract on this contract because of race, religion, color, age, disability, sex, sexual orientation, gender identity or national origin.

The Contractor agrees that within thirty (30) days after the effective date of this agreement, the Contractor will provide to the City Affirmative Action Division certain workforce utilization statistics, using a form to be furnished by the City.

If the contract is still in effect, or if the City enters into a new agreement with the Contractor, within one year after the date on which the form was required to be provided, the Contractor will provide updated workforce information using a second form, also to be furnished by the City. The second form will be submitted to the City Affirmative Action Division no later than one year after the date on which the first form was required to be provided.

The Contractor further agrees that, for at least twelve (12) months after the effective date of this contract, it will notify the City Affirmative Action Division of each of its job openings at facilities in Dane County for which applicants not already employees of the Contractor are to be considered.

The notice will include a job description, classification, qualifications and application procedures and deadlines. The Contractor agrees to interview and consider candidates referred by the Affirmative Action Division if the candidate meets the minimum qualification standards established by the Contractor, and if the referral is timely. A referral is timely if it is received by the Contractor on or before the date started in the notice.

Articles of Agreement
Article I

The Contractor shall take affirmative action in accordance with the provisions of this contract to insure that applicants are employed, and that employees are treated during employment without regard to race, religion, color, age, marital status, disability, sex, sexual orientation, gender identity or national origin and that the employer shall provide harassment free work environment for the realization of the potential of each employee. Such action shall include, but not be limited to, the following: employment, upgrading, demotion or transfer, recruitment or recruitment advertising, layoff or termination, rates of pay or other forms of compensation and selection for training including apprenticeship insofar as it is within the control of the Contractor. The Contractor agrees to post in conspicuous places available to employees and applicants notices to be provided by the City setting out the provisions of the nondiscrimination clauses in this contract.

Article II

The Contractor shall in all solicitations or advertisements for employees placed by or on behalf of the Contractors state that all qualified or qualifiable applicants will be employed without regard to race, religion, color, age, marital status, disability, sex, sexual orientation, gender identity or national origin.

Article III

The Contractor shall send to each labor union or representative of workers with which it has a collective bargaining agreement or other contract or understanding a notice to be provided by the City advising the labor union or worker's representative of the Contractor's equal employment opportunity and affirmative action commitments. Such notices shall be posted in conspicuous places available to employees and applicants for employment.

Article V

The Contractor agrees that it will comply with all provisions of the Affirmative Action Ordinance of the City of Madison, including the contract compliance requirements. The Contractor agrees to submit the model affirmative action plan for public works contractors in a form approved by the Affirmative Action Division Manager.

Article VI

The Contractor will maintain records as required by Section 39.02(9)(f) of the Madison General Ordinances and will provide the City Affirmative Action Division with access to such records and to persons who have relevant and necessary information, as provided in Section 39.02(9)(f). The City agrees to keep all such records confidential, except to the extent that public inspection is required by law.

Article VII

In the event of the Contractor's or subcontractor's failure to comply with the Equal Employment Opportunity and Affirmative Action Provisions of this contract or Section 39.03 and 39.02 of the Madison General Ordinances, it is agreed that the City at its option may do any or all of the following:

1. Cancel, terminate or suspend this Contract in whole or in part.
2. Declare the Contractor ineligible for further City contracts until the Affirmative Action requirements are met.
3. Recover on behalf of the City from the prime Contractor 0.5 percent of the contract award price for each week that such party fails or refuses to comply, in the nature of liquidated damages, but not to exceed a total of five percent (5%) of the contract price, or ten thousand dollars (\$10,000), whichever is less. Under public works contracts, if a subcontractor is in noncompliance, the City may recover liquidated damages from the prime Contractor in the manner described above. The preceding sentence shall not be construed to prohibit a prime Contractor from recovering the amount of such damage from the non-complying subcontractor.

Article VIII

The Contractor shall include the above provisions of this contract in every subcontract so that such provisions will be binding upon each subcontractor. The Contractor shall take such action with respect to any subcontractor as necessary to enforce such provisions, including sanctions provided for noncompliance.

Article IX

The Contractor shall allow the maximum feasible opportunity to small business enterprises to compete for any subcontracts entered into pursuant to this contract. (In federally funded contracts the terms "DBE, MBE and WBE" shall be substituted for the term "small business" in this Article.)

5. Substance Abuse Prevention Program Required. Prior to commencing work on the Contract, the Contractor, and any Subcontractor, shall have in place a written program for the prevention of substance abuse among its employees as required under Wis. Stat. Sec. 103.503.
6. **Contractor Hiring Practices.**

Ban the Box - Arrest and Criminal Background Checks. (Sec. 39.08, MGO)

This provision applies to all prime contractors on contracts entered into on or after January 1, 2016, and all subcontractors who are required to meet prequalification requirements under MGO 33.07(7)(l), MGO as of the first time they seek or renew pre-qualification status on or after January 1, 2016. The City will monitor compliance of subcontractors through the pre-qualification process.

- a. **Definitions.** For purposes of this section, "Arrest and Conviction Record" includes, but is not limited to, information indicating that a person has been questioned, apprehended, taken into custody or detention, held for investigation, arrested, charged with, indicted or tried for any felony, misdemeanor or other offense pursuant to any law enforcement or military authority.

"Conviction record" includes, but is not limited to, information indicating that a person has been convicted of a felony, misdemeanor or other offense, placed on probation, fined, imprisoned or paroled pursuant to any law enforcement or military authority.

"Background Check" means the process of checking an applicant's arrest and conviction record, through any means.

- b. **Requirements.** For the duration of this Contract, the Contractor shall:

1. Remove from all job application forms any questions, check boxes, or other inquiries regarding an applicant's arrest and conviction record, as defined herein.
2. Refrain from asking an applicant in any manner about their arrest or conviction record until after conditional offer of employment is made to the applicant in question.
3. Refrain from conducting a formal or informal background check or making any other inquiry using any privately or publicly available means of obtaining the arrest or conviction record of an applicant until after a conditional offer of employment is made to the applicant in question.
4. Make information about this ordinance available to applicants and existing employees, and post notices in prominent locations at the workplace with information about the ordinance and complaint procedure using language provided by the City.
5. Comply with all other provisions of Sec. 39.08, MGO.

c. Exemptions: This section shall not apply when:

1. Hiring for a position where certain convictions or violations are a bar to employment in that position under applicable law, or
2. Hiring a position for which information about criminal or arrest record, or a background check is required by law to be performed at a time or in a manner that would otherwise be prohibited by this ordinance, including a licensed trade or profession where the licensing authority explicitly authorizes or requires the inquiry in question.

To be exempt, Contractor has the burden of demonstrating that there is an applicable law or regulation that requires the hiring practice in question, if so, the contractor is exempt from all of the requirements of this ordinance for the position(s) in question.

**CHIP SEALING 2020 - EAST
CONTRACT NO. 8509**

IN WITNESS WHEREOF, the Contractor has hereunto set his/her hand and seal and the City has caused this contract to be sealed with its corporate seal and to be executed by its Mayor and City Clerk on the dates written below.

Countersigned:

Carlo M. Hazell 4/1/2020
Date
Witness
Raykowski 4/1/2020
Date

SCOTT CONSTRUCTION INC.

Company Name

[Signature] 4/1/2020
Date
Vice President Jana A. Scott
[Signature] 4/1/2020
Date
Secretary Stephen T. Heiser

CITY OF MADISON, WISCONSIN

Provisions have been made to pay the liability that will accrue under this contract.

[Signature] 4/14/2020
Date
Finance Director
[Signature] 4/21/2020
Date
Witness
[Signature]
Date

Approved as to form:

[Signature] 4/17/2020
Date
City Attorney
[Signature] 4/21/20
Date
Mayor
Maibeth Witzel-Behl 4-9-2020
Date
City Clerk



SECTION I: PAYMENT AND PERFORMANCE BOND

KNOW ALL MEN BY THESE PRESENTS, that we SCOTT CONSTRUCTION INC. as principal, and Fidelity and Deposit Company of Maryland Company of Maryland as surety, are held and firmly bound unto the City of Madison, Wisconsin, in the sum of ONE MILLION FIVE HUNDRED FIFTY-TWO THOUSAND TWO HUNDRED NINETY-SIX AND 84/100 (\$1,552,296.84) Dollars, lawful money of the United States, for the payment of which sum to the City of Madison, we hereby bind ourselves and our respective executors and administrators firmly by these presents.

The condition of this Bond is such that if the above bounden shall on his/her part fully and faithfully perform all of the terms of the Contract entered into between him/herself and the City of Madison for the construction of:

**CHIP SEALING 2020 - EAST
CONTRACT NO. 8509**

in Madison, Wisconsin, and shall pay all claims for labor performed and material furnished in the prosecution of said work, and save the City harmless from all claims for damages because of negligence in the prosecution of said work, and shall save harmless the said City from all claims for compensation (under Chapter 102, Wisconsin Statutes) of employees and employees of subcontractor, then this Bond is to be void, otherwise of full force, virtue and effect.

Signed and sealed this 1st day of April, 2020

Countersigned:

[Signature]
Witness
[Signature]
Secretary Steven T. Heiser

SCOTT CONSTRUCTION INC.

Company Name (Principal)

[Signature]
Vice President John A. Scott Seal

Approved as to form:

[Signature]
City Attorney

Fidelity and Deposit Company of Maryland

Surety

Seal

Salary Employee Commission

By

[Signature]
Attorney-in-Fact Patrick A McKenna

This certifies that I have been duly licensed as an agent for the above company in Wisconsin under National Producer Number 650765 for the year 2020, and appointed as attorney-in-fact with authority to execute this payment and performance bond which power of attorney has not been revoked.

April 1, 2020
Date

[Signature]
Agent Signature

**ZURICH AMERICAN INSURANCE COMPANY
COLONIAL AMERICAN CASUALTY AND SURETY COMPANY
FIDELITY AND DEPOSIT COMPANY OF MARYLAND
POWER OF ATTORNEY**

KNOW ALL MEN BY THESE PRESENTS: That the ZURICH AMERICAN INSURANCE COMPANY, a corporation of the State of New York, the COLONIAL AMERICAN CASUALTY AND SURETY COMPANY, a corporation of the State of Illinois, and the FIDELITY AND DEPOSIT COMPANY OF MARYLAND a corporation of the State of Illinois (herein collectively called the "Companies"), by **Robert D. Murray, Vice President**, in pursuance of authority granted by Article V, Section 8, of the By-Laws of said Companies, which are set forth on the reverse side hereof and are hereby certified to be in full force and effect on the date hereof, do hereby nominate, constitute, and appoint, **Judith A. WALKER, Elizabeth MOSCA, David ZENOBI, Patrick A. MCKENNA and Brooke L. PARKER, all of Madison, Wisconsin**, Each, its true and lawful agent and Attorney-in-Fact, to make, execute, seal and deliver, for, and on its behalf as surety, and as its act and deed: any and all bonds and undertakings, **EXCEPT bonds on behalf of Independent Executors, Community Survivors and Community Guardians**, and the execution of such bonds or undertakings in pursuance of these presents, shall be as binding upon said Companies, as fully and amply, to all intents and purposes, as if they had been duly executed and acknowledged by the regularly elected officers of the ZURICH AMERICAN INSURANCE COMPANY at its office in New York, New York., the regularly elected officers of the COLONIAL AMERICAN CASUALTY AND SURETY COMPANY at its office in Owings Mills, Maryland., and the regularly elected officers of the FIDELITY AND DEPOSIT COMPANY OF MARYLAND at its office in Owings Mills, Maryland., in their own proper persons.

The said Vice President does hereby certify that the extract set forth on the reverse side hereof is a true copy of Article V, Section 8, of the By-Laws of said Companies and is now in force.

IN WITNESS WHEREOF, the said Vice-President has hereunto subscribed his/her names and affixed the Corporate Seals of the said **ZURICH AMERICAN INSURANCE COMPANY, COLONIAL AMERICAN CASUALTY AND SURETY COMPANY, and FIDELITY AND DEPOSIT COMPANY OF MARYLAND**, this 27th day of February, A.D. 2020.



**ATTEST:
ZURICH AMERICAN INSURANCE COMPANY
COLONIAL AMERICAN CASUALTY AND SURETY COMPANY
FIDELITY AND DEPOSIT COMPANY OF MARYLAND**

By: *Robert D. Murray*
Vice President

By: *Dawn E. Brown*
Secretary

**State of Maryland
County of Baltimore**

On this 27th day of February, A.D. 2020, before the subscriber, a Notary Public of the State of Maryland, duly commissioned and qualified, **Robert D. Murray, Vice President and Dawn E. Brown, Secretary** of the Companies, to me personally known to be the individuals and officers described in and who executed the preceding instrument, and acknowledged the execution of same, and being by me duly sworn, deposed and saith, that he/she is the said officer of the Company aforesaid, and that the seals affixed to the preceding instrument are the Corporate Seals of said Companies, and that the said Corporate Seals and the signature as such officer were duly affixed and subscribed to the said instrument by the authority and direction of the said Corporations.

IN TESTIMONY WHEREOF, I have hereunto set my hand and affixed my Official Seal the day and year first above written.



Constance A. Dunn

Constance A. Dunn, Notary Public
My Commission Expires: July 9, 2023

EXTRACT FROM BY-LAWS OF THE COMPANIES

"Article V, Section 8, Attorneys-in-Fact. The Chief Executive Officer, the President, or any Executive Vice President or Vice President may, by written instrument under the attested corporate seal, appoint attorneys-in-fact with authority to execute bonds, policies, recognizances, stipulations, undertakings, or other like instruments on behalf of the Company, and may authorize any officer or any such attorney-in-fact to affix the corporate seal thereto; and may with or without cause modify or revoke any such appointment or authority at any time."

CERTIFICATE

I, the undersigned, Vice President of the ZURICH AMERICAN INSURANCE COMPANY, the COLONIAL AMERICAN CASUALTY AND SURETY COMPANY, and the FIDELITY AND DEPOSIT COMPANY OF MARYLAND, do hereby certify that the foregoing Power of Attorney is still in full force and effect on the date of this certificate; and I do further certify that Article V, Section 8, of the By- Laws of the Companies is still in force.

This Power of Attorney and Certificate may be signed by facsimile under and by authority of the following resolution of the Board of Directors of the ZURICH AMERICAN INSURANCE COMPANY at a meeting duly called and held on the 15th day of December 1998.

RESOLVED: "That the signature of the President or a Vice President and the attesting signature of a Secretary or an Assistant Secretary and the Seal of the Company may be affixed by facsimile on any Power of Attorney...Any such Power or any certificate thereof bearing such facsimile signature and seal shall be valid and binding on the Company."

This Power of Attorney and Certificate may be signed by facsimile under and by authority of the following resolution of the Board of Directors of the COLONIAL AMERICAN CASUALTY AND SURETY COMPANY at a meeting duly called and held on the 5th day of May, 1994, and the following resolution of the Board of Directors of the FIDELITY AND DEPOSIT COMPANY OF MARYLAND at a meeting duly called and held on the 10th day of May, 1990.

RESOLVED: "That the facsimile or mechanically reproduced seal of the company and facsimile or mechanically reproduced signature of any Vice-President, Secretary, or Assistant Secretary of the Company, whether made heretofore or hereafter, wherever appearing upon a certified copy of any power of attorney issued by the Company, shall be valid and binding upon the Company with the same force and effect as though manually affixed.

IN TESTIMONY WHEREOF, I have hereunto subscribed my name and affixed the corporate seals of the said Companies, this 1st day of April, 2020.



Brian M. Hodges

By: Brian M. Hodges
Vice President

TO REPORT A CLAIM WITH REGARD TO A SURETY BOND, PLEASE SUBMIT A COMPLETE DESCRIPTION OF THE CLAIM INCLUDING THE PRINCIPAL ON THE BOND, THE BOND NUMBER, AND YOUR CONTACT INFORMATION TO:

Zurich Surety Claims
1299 Zurich Way
Schaumburg, IL 60196-1056
www.reportsfclaims@zurichna.com
800-626-4577